



**Suprith Kubatur Sudhama, Luis Perez Martinez, Mike Kolkman, Tim Belshof & Nick Kroep**

**Smart Solution Semester**

6 July 2018

Saxion Enschede  
Life Science, Engineering & Design  
Smart Solution Semester  
Postbus 70.000  
7500 KB Enschede  
(053) 4871111  
[www.saxion.nl](http://www.saxion.nl)

## Abstract

This project involves creating a demonstration model of the Greensource solutions. The Greensource solution is a way to harvest, collect and clean rainwater to use it for consumption and irrigation. It uses high tech membrane, activated carbon and UV-C filtration to improve the rainwater to drinking water.

The first phase of this project is the design of the demonstration model, including a filter system, monitoring system and control system. By means of the Zeiler method the different functions of the system are determined. For these functions some solutions have been devised and in a morphological overview some combinations of solutions are combined to a proposed concept. These are valued and the best becomes the basis for the final concept. The final concept of the demonstration model consists out of a filtering unit with a membrane filter and UV-C filter. The electrical system includes a Siemens Logo! as a main component, this device monitors and controls the other system elements like the pumps, valves and sensors. The monitoring system contains a Raspberry Pi with digital sensors to measure the different values to display on the main screen.

The second phase of this project is the constructing of the designed demonstration model. The proper assembly of the different parts is important in order to guarantee a good functioning of the product. In this phase an adjusted piping and instrumentation diagram (P&ID) was created. To resemble the original Greensource idea, the new P&ID is based on the original one. The power supply had also been ensured, therefore the team has devised an electrical design with fuses, relays etcetera. In preparation for the connection and testing of the electrical components and the PLC, a control program has been created for the Siemens Logo!. Regrettably the team could not implement the control system anymore. With regard to the operating systems, the project team concludes that it would have been better to first start on the electrical design, power supply, then with the control system.

Unfortunately, the demonstration model is not completely finished yet. The team got the model working at the smart solution festival through a temporary adjustment. Most of the originally planned parts have now been assembled, but not all of these parts have arrived on time and therefore have not yet been assembled. The current state of the demonstration model is that all cover plates are mounted but that the piping is not yet finished. The electrical system is mounted, but not yet connected. Identical like the monitoring system. The project team concludes that better inventory with regard to the duration of different processes would help with keeping the project on schedule. For example, order processes, development processes and so on. Furthermore, another conclusion is that it is essential to have better and clearer consultations with stakeholders regarding technical support and orders.

## Preface

Before you lies the report of “Water A.I.D.E.D.”, a project with the aim to build a demonstration model. It has been written to fulfil the requirements of the Smart Solutions Semester at the Saxion University of Applied Sciences. We were engaged in establishing and producing a water filtering demonstration model from February to June 2018.

The project was undertaken at the request of Mr. Futselaar, head of lectorate International Water Technology. The development was difficult, but conducting extensive investigation had allowed us to find, in our opinion, the best solution. Fortunately, both Mr. Futselaar and our tutor, Mr. Timmers, were always available and willing to answer our queries.

We would like to thank the companies, Jotem, Van Remmen and JoinThePipe for their guidance and support during this process. We also wish to thank Mr. Jannink, without whose cooperation we would not have been able to build the demonstration model.

To our other students at Saxion.: We would like to thank you for your pleasant cooperation as well. It was always helpful to bat ideas about our research around with you. We also benefited from debating issues with our friends and family. If we ever lost interest, you kept us motivated.

We hope you enjoy your reading.

The Water A.I.D.E.D. team,

Suprith Kubatur Sudhama, Luis Perez Martinez, Mike Kolkman, Tim Belshof & Nick Kroep

Enschede, 6 July, 2018.

# Table of content

Abstract .....	ii
Preface.....	iii
Table of content .....	iv
<b>1. Introduction .....</b>	<b>1</b>
1.1 General background.....	2
1.2 Technical background.....	4
<b>2. Methodology .....</b>	<b>8</b>
<b>3. Designing .....</b>	<b>12</b>
3.1 Research .....	12
3.2 Morphological overview .....	13
3.3 Concept .....	13
3.4 Piping calculation.....	14
3.5 Component selection .....	15
3.6 3D-model .....	16
3.7 Frame calculations .....	18
<b>4. Control system.....</b>	<b>22</b>
<b>5. Monitoring system .....</b>	<b>23</b>
5.1 Introduction.....	23
5.2 Problem defining .....	23
5.3 Determining method phase .....	23
5.4 Selection phase.....	25
5.5 Design phase .....	26
<b>6. Discussion .....</b>	<b>29</b>
6.1 Demonstration model .....	29
6.2 Components .....	29
6.3 Control and monitoring system .....	30
<b>7. Conclusion.....</b>	<b>31</b>
<b>8. Recommendations.....</b>	<b>32</b>

<b>References .....</b>	<b>33</b>
<b>Appendix .....</b>	<b>35</b>
<i>Appendix 1. Monitoring Codes .....</i>	<i>35</i>
<i>Appendix 2. Webpage .....</i>	<i>55</i>
<i>Appendix 3. Lineguard .....</i>	<i>56</i>
<i>Appendix 4. UV Water filters .....</i>	<i>60</i>
<i>Appendix 5. Activated carbon filter .....</i>	<i>61</i>
<i>Appendix 6. Crates.....</i>	<i>62</i>
<i>Appendix 7. Artificial pitch.....</i>	<i>64</i>
<i>Appendix 8. Siemens Logo! Program.....</i>	<i>66</i>
<i>Appendix 9. Concepts .....</i>	<i>72</i>
<i>Appendix 10. Electrical design .....</i>	<i>77</i>
<i>Appendix 11. P&amp;ID .....</i>	<i>86</i>
<i>Appendix 12. 2D-drawings .....</i>	<i>87</i>
<i>Appendix 13. SFC.....</i>	<i>91</i>
<i>Appendix 14. Morphological overview.....</i>	<i>100</i>

**Figure list**

Figure 1 – Global physical and economic water scarcity (Unesco, 2012) ..... 2

Figure 2 – Completed functional design Greensource South Africa ..... 4

Figure 3 – Cross section of a Greensource pitch ..... 4

Figure 4 – Sustainable Development Goals United Nations ..... 6

Figure 5 – JoinThePipe tap with children ..... 7

Figure 6 – Requirements, wishes, extra's and boundaries ..... 9

Figure 7 – Demonstration model trailer ..... 12

Figure 8 – Final concept ..... 13

Figure 9 – Frame ..... 16

Figure 10 – Frame with components ..... 17

Figure 11 – Final Render ..... 17

Figure 12 – Bottom frame ..... 18

Figure 13 – Free body sketch ..... 19

Figure 14 – D-line ..... 19

Figure 15 – M-line ..... 19

Figure 16 – P&ID part dirty water tank ..... 20

Figure 17 – P&ID part lineguard ..... 21

Figure 18 – Morphological overview monitoring part ..... 23

Figure 19 – Monitoring System ..... 26

Figure 20 – Connections Raspberry Pi ..... 27

Figure 21 – Monitoring App Water A.I.D.E.D. .... 28

Figure 22 – Windows Form application ..... 35

Figure 23 – Screenshot website Water A.I.D.E.D. .... 55

Figure 24 – Lineguard UF-100 ..... 56

Figure 25 – Connections Lineguard ..... 58

Figure 26 – Lineguard dimensions ..... 59

Figure 27 – UV light frequencies (Xtreme water systems, sd) ..... 60

Figure 28 – Crate ..... 62

Figure 29 – Specifications crates ..... 63

Figure 30 – Layers artificial pitch ..... 64

Figure 31 – Example artificial grass ..... 64

Figure 32 – Layers damping ..... 65

Figure 33 – Specifications TS Polyfelt ..... 65

Figure 34 – Geotextile ..... 65

Figure 35 – Inputs & outputs ..... 66

Figure 36 – Tank 1 Fill ..... 67

Figure 37 – Tank 3 Fill ..... 68

Figure 38 – Tank 3 Fill ..... 69

Figure 39 – Small loop ..... 70

Figure 40 – Backwash ..... 71

Figure 41 – Concept 1 ..... 72

Figure 42 – Concept 2 ..... 72

Figure 43 – Concept 3 ..... 73

Figure 44 – Concept 4 ..... 73

Figure 45 – Concept 5 ..... 74  
Figure 46 – Concept 6 ..... 74  
Figure 47 – Concept 7 ..... 75  
Figure 48 – Concept 8 ..... 75

# 1. Introduction

Clean water scarcity is a very big problem and this can potentially be an even bigger problem. 844 million people lack a basic drinking-water service and globally at least 2 billion people use a drinking water source which is contaminated (World Health Organization, 2018). These are some disturbing facts, but it is only getting worse. The World Health Organization (World Health Organization, 2017) claims: “in 2025 half of the world’s population will be living in water-stressed areas”. Therefore, water scarcity is a worrying development that is full of danger for a large part of the population of the world.

Water scarcity could have a large impact on the modern society. Not having sufficient clean drinking water has a major impact on social and economic levels (UN, 2014). For example, in Figure 1 the global physical and economic water scarcity are shown. There are already many projects (GreenSource, 2016) (Water For Africa, 2018) (The Water Project, 2018) that aim to provide clean water in areas with water scarcity, but there is still enough work that must be done.

The Greensource solution collects rainwater and wellwater by means of a small soccer pitch and uses ultrafiltration which is capable of removing contaminations in order to provide safe drinking water. In addition, the Greensource provides a playground where children and the rest of the community can meet each other (GreenSource, 2018). The combination of water storage and a sports field is chosen so that the field is not only of value by providing water, but also by enabling sports and games. Therefore, if the system has a social interest, the users will also take better care of it.

Nelson Mandela (Mandela, 2003) said: “Education is the most powerful weapon which you can use to change the world”. All over the world there are many good projects that produce or try to produce clean drinking water in countries that have a lack of it. However, local people are often not sufficiently trained to deal with the complicated systems. The consequences of misuse or the lack of maintenance can be very large (Mohsenin, 2016).

In the most European countries it is usual to drink clean water directly from the tap. In several other countries, such as South Africa, it is much harder to provide a source of clean drinking water as well as to distribute it directly from a tap system. In the Netherlands, for example, this is problem is not present day, therefore there is not enough awareness of the clean water scarcity elsewhere in the world. Additionally, the solutions that have already been devised are not very well known. To make people aware of the water scarcity problem and the Greensource solution of water filtering, providing information is essential. One of the best ways to provide people with information is through a demonstration. A good demonstration model of the Greensource solution of making clean drinking water is required. This can make clear what a good water filtering system can mean for the world. This project, called Water A.I.D.E.D., will create a demonstration model as an example for the already created water filter installations and to create more awareness and use the model for educational purposes.



This project is based on the work done by previous groups. (Wigbers, Slagers, Hofstee, Slot, & Al Zadjali, 2018)

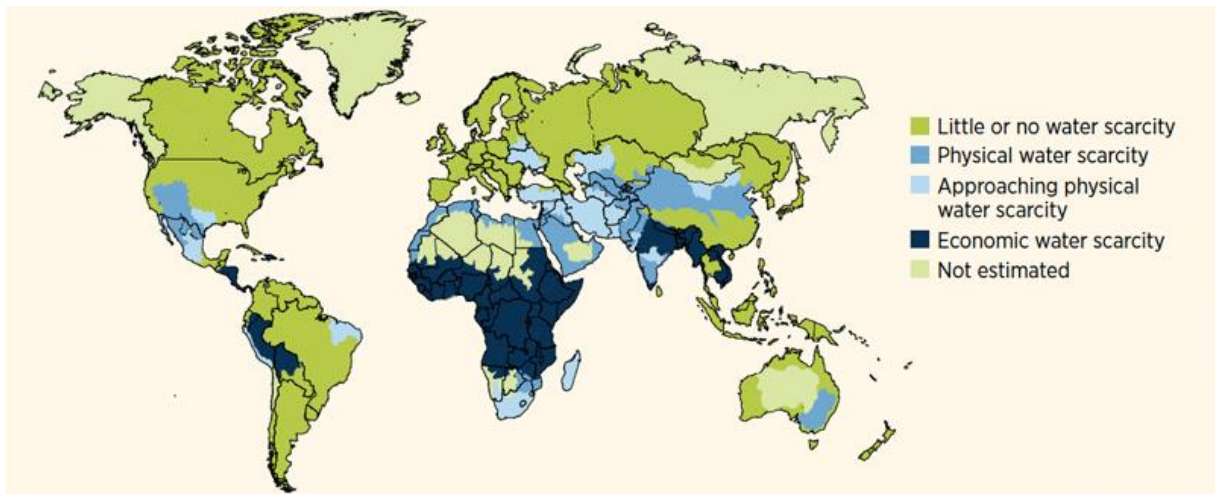

Figure 1 – Global physical and economic water scarcity (Unesco, 2012)

### ***1.1 General background***

The International Water Technology is a project created by Saxion University of Applied Science to create fresh water in different parts of the world. The International Water Technology is included in the research line of "Water and Materials".

#### **Example city for future problems.**

Cape town is south Africa's second largest city and a top International tourist attract. Now residents play a new and delicate game of water math each day. More than half of all Africans lack access to safe drinking water. Cape town is suffering through an extreme water crisis. For months, the city of four million people has been facing a doomsday scenario of the taps running dry.

Dams levels are drastically getting low, life altering emergency water restrictions have been implemented to prevent the catastrophe.

The residents have been living a daily allowance of just 50 litres of water a day. Aggressive Capetonians have been stocking water and installing the tanks. For many people out there, the day starts standing in line at a natural spring to collect the water for the family.

Population growth and a record drought perhaps enraged by the climate change has arouse one of the world's most dramatic urban water crisis. As south African leaders warn that residents are likely to face "day Zero" that is the day where the taps running dry.

#### **Approaching "Day Zero"**

The city is taking as strong action by installing 200 emergency water stations outside groceries and other main spots. The country officials have made plans of storing emergency water at military installations, and declares using taps to fill pools, water gardens, or wash cars is now illegal. They are asked to crack down on "unscrupulous traders" who have driven up the price of bottled water.

South Africa is experiencing its worst drought since 1921, with last year being the driest on record. This water scarcity had considerable effects on the economy and societies across the country, and need for the innovative solutions, technologies, and highly skilled individuals that will help ease the negative effects of drought.

In attempts to prevent South Africa's water crisis, the water RDI opens to stakeholders which is created by the Department of Science and Technology and Water Research Commission (WRC). WRC will be hosting a roadshow throughout major cities across the country to present a finalized plan to interested stakeholders. The roadshow will provide stakeholders with an opportunity to engage with instruments that have been out in place to support the implementation of the roadmap. Stakeholders will also have an opportunity to investigate or discuss how institutions could give their best and engage themselves with the water RDI roadmap.

### **Water Scarcity**

In the Netherlands someone can turn the tap on and there comes clean drinking water out of it, but not everywhere in the world this is normal. There are far too many people in the world who do not have access to clean (drinking) water, so there is water scarcity. (Ganter, 2015)

Water scarcity is the shortage of fresh water resources, but there are different types of water scarcity. There is physical and economical water scarcity and the difference is caused by a lack of investment in water infrastructure or insufficient human capacity to satisfy the demand of water in areas where the population cannot afford to use an adequate source of water. Both types of water scarcity the people do not have clean drinking water. Physical water scarcity it does not benefit the effectivity of the ecosystems. Symptoms of physical water scarcity are severe environmental degradation, declining groundwater and water allocations that favour some groups over others.

Symptoms of economic water scarcity include a lack of infrastructure, where people often have to walk for domestic and agricultural use to rivers or lakes to get water. This water is obviously not drinkable and will also have to undergo substantial filtration to become drinking water. (Food and Agriculture Organization of the United Nations, 2012)

### **GreenSource completed projects in South Africa.**

Four filtering units are already built in South Africa. These filtering units use the surface of a small size soccer pitch for collecting rainwater and the special foundation of these pitches to store the rain water. The foundation consists of special crates that can store a lot of water. When drinking water is needed the system will filter the water and create clean (drinking) water. The problem with the system is the designers and researchers cannot test it over there. Additionally, when the system has a problem, the people in South Africa do not know how to fix the problem.

## 1.2 Technical background

In figure 2 you can see the functional design of the completed filtering units. The main parts are pictured: the pitch with the several layers, the filter unit and the piping.

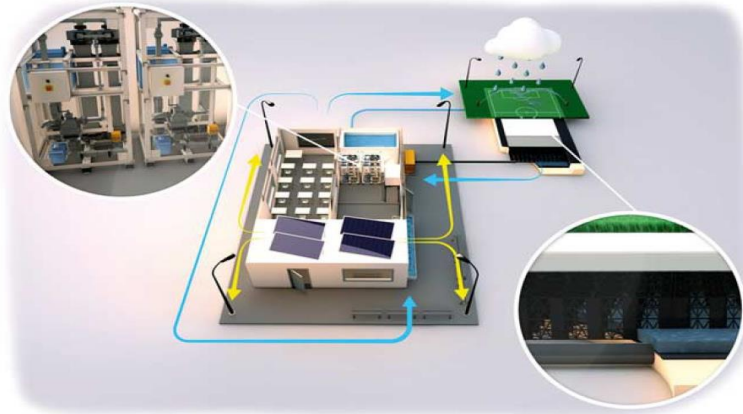

Figure 2 – Completed functional design Greensource South Africa

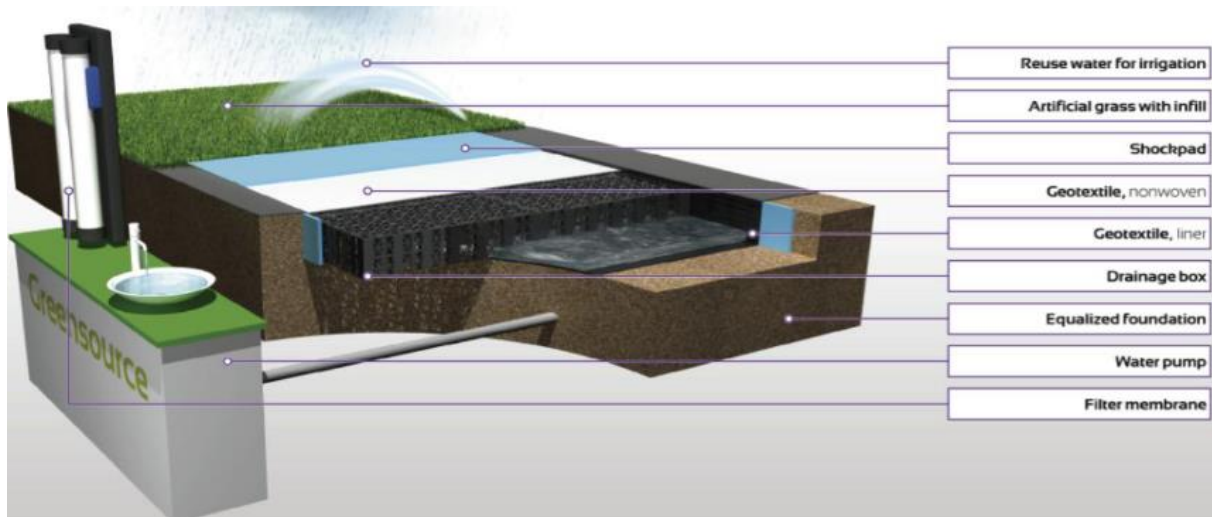

Figure 3 – Cross section of a Greensource pitch

This pitch is made of crates to create a stable and horizontal place to install the artificial grass to play football and to collect all the rain water. This rain water can then be filtered to create clean drinking water (GreenSource, 2018). This pitch is made of crates to create a stable and horizontal place to install the artificial grass to play football and to collect all the rain water. The little pitch that we are going to build would have the same principle and working. (GreenSource, 2018)

### Previous group: 1617S

The 1617s group had an assignment that consisted of 3 parts. They did a research on a surrogate challenge test. So how could they replace the difficult lab test by an easier on-site test. They also constructed educational videos for illiterate people on how to operate the system. The last part they have investigated is an intelligent tap system to determine if a tapping point has been used recently.

The results of the first integrity test were inconclusive. It was not possible with the equipment at hand to measure the small concentration of nanoparticles. The second integrity test, the simpler method, showed that it is possible to check if the system is still integer. But still more research needs to be done, because the project group did not do a simulation in which, for example, leaks occurred. For the educational videos, the system of Tap21 has been modelled in SolidWorks by the 1617S group. This model is used in an animation that will provide an effective learning method for all standards of education. The project group created an intelligent tap system. The design consists of a generator, a supercapacitor with a Perlator, a LED and an Attiny85 which operates the system. Further research on the use of this system has to be done. (Bekkema, Kalma, Schadenberg, Schigt, & Whelan, 2017)

This information and research is mainly about integrity tests and it does not have much to do with the subject that is being discussed in this project. The educational videos are important since there is the desire to make new videos.

### **Previous group:1718F**

The 1718F group had two main goals on their project. First of all, find a new way or develop a method to test the integrity of the membrane. Second, the system should work automatically which means the system has to filter the water as well as to clean itself.

The previous group has worked on creating all the parts that controlled the filtering unit and put all the components together and make sure that it works. To achieve this, they used a Siemens Logo, which is a PLC (programmable logic controller). The PLC is an industrial digital computer which has been ruggedized and adapted for the control of manufacturing processes. But this controller has a series of disadvantages like that it has closed software, limited functionality and it can only be controlled and program for/by an electric engineer.

The group did test the pressure decay test, but they were not able to assemble the system. The parts for the system did not arrive on time. The second goal has not been achieved. (Wigbers, Slagers, Hofstee, Slot, & Al Zadjali, 2018)

The information and research about the pressure decay test is specific information about the line guard. The line guard is not the main subject of the current project. However, the information about the PLC is relevant because there will be a PLC in the demonstration model.

### **Stakeholders**

All companies that support the project are highly valued, but of course every company will have an interest in cooperating with a project. This can go in many different directions. Every company has its own goals and these goals will be respected. The targets will be displayed for some companies. Every company wants to express its support from its own consideration or vision.

**Pentair:** Pentair is a global company that wants to exert a positive influence on the world with its technology, resources and values. Pentair focuses its programs on corporate responsibility and exploring societal challenges in the areas of water, food and energy, sustainability and getting involved with their communities is of paramount importance. (Pentair, 2018)

TenCate: Ten Cate uses the new seventeen Sustainable Development Goals (Figure 4) that have been compiled by the UN. They respond to these goals by participating in various projects. Ten Cate does not only support the Greensource project, but also “Field in a box™”. (Ten Cate, 2018)

IWT : The IWT, International water technology, one of his goals is to aware people of scarcity of water in development countries, conscience people about save water and use in responsible way. For accomplished this objective, our client told us to make a demonstration model in order to use in scientist exhibition and open days, and student and people interested will be able to see the possible solutions and the organization vision. (Futselaar, Harry, 2018)

Mmapula : Mmapula Community Development is company with several goals. For example, they want to educate, improve rural and township transformation, improve enterprise development, improve human development, transform the rural and township and the want to stay open for change. Actually, they want to improve the country South–Africa in all the ways they can, from water filtration to human development. (Mmapula, 2018)

Jotem: Jotem Water Treatment is an experienced specialist in issues concerning pipeline, source, surface, sea and waste water. (Jotem Waterbehandeling B.V., 2018) Jotem is currently the only builder / compiler of the containers with the filter systems that are shipped to South Africa.

Van Remmen: Van Remmen makes UV disinfection systems for liquids and surfaces. Van Remmen has their own research and development department with which they have a lot of knowledge about UV filter technology.

Of course, every company will also want their contribution, in the form of a product, to be put in a good light. Supporting the charity is always a good way of bringing out your brand / company / product. The most of the already mentioned companies pursue the global goals of the United Nations. (Figure 4)



Figure 4 – Sustainable Development Goals United Nations

### **Components Greensource solution**

The Greensource solution of water filtering consists out of three main filter parts. First of all, the membrane filter, the Water miracle of Pentair. Second, an activated carbon filter of the company Jotem is equipped. The final filter is a UV filter of the company Van Remmen to kill all bacteria, parasites and viruses. More detailed information is given in appendix three to seven.

The Greensource solutions uses JoinThePipe taps to distribute the water, as shown below in Figure 5. And for obvious reasons, use is also made of different pumps, valves and other appendages.



**Figure 5 – JoinThePipe tap with children**

## 2. Methodology

### Introduction

The methodology is important part of the project, but before the group can use a methodology they have to know what they have to do this semester.

The client had many possible projects. He also had many “problems” that the group could solve. The group get in contact with the client and they talked with each other. The client gave the group the advice to look at the previous groups what they have done. After they read the other project reports they came again in contact with the client and they had several conversations.

In these conversations it turned out that the client was openminded and he also want the group do things they will like. He said working on a project that everyone thinks it nice, will have a better result for the project, but also a nicer semester for the group.

As result of this they came in a conversation and asked each other what they expected of this semester. In one of these conversations the group and the client came at the point that they found out that there is not enough awareness of the problem of water scarcity and of the project. In this way they came out with a project of starting with a demonstration model for the client. He can use this for exhibitions and to create more awareness of the project and the water scarcity problem.

### Requirements and goals

Now the problem of finding a project/problem to solve this semester was settled. The group started with the project himself and that means to set up the requirements and goals.

The MoSCoW-method was used for this and as defined in the project plan the demonstration model must meet certain requirements. In addition to the hard requirements, there are some wishes and even some extra's. These requirements are stated in the figure, Figure 6, on the next page and if you want more information you will be referred to the project plan.

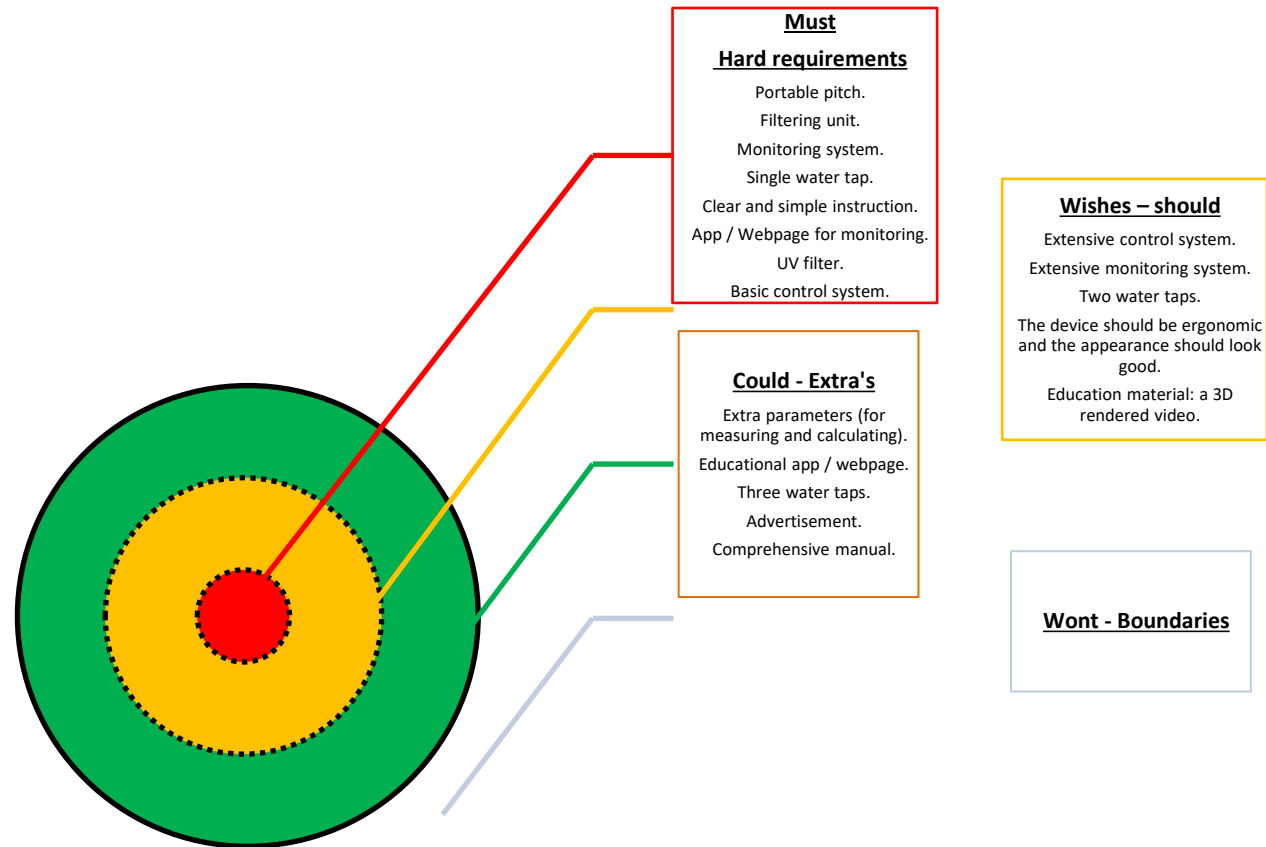

Figure 6 – Requirements, wishes, extra's and boundaries



## Methodology

The requirements and goals are made and now the group start to reach the project. As told in the project plan they will use the Zeiler method. In the Zeiler methodology there are 4 phases to be used for a designing project. These phases are based on defining the problem, determining the method, selection part and at last designing phase.

At first the group will define the problem, what does the client want and how do the group fill in the project. The client wanted a demonstration model of the already existing Greensource project in South-Africa. He wanted to show the principle of the filtration system and create awareness of the water scarcity problem. This demonstration model has to be easily transported and give the visitor clean drinking water.

The second phase is the determining phase and they had to do research on the existing project. The demonstration model will show the problem, the filtration system and will exist of clean drinking water for the visitor. If the group wanted to show this, they need different components from different suppliers, but not every dimension is there yet. What size should it be and how will it look? To answer these it to soon, but with the new phase the group will start to answer this.

The determining phase is done and now the selection could start. The requirements are set up and for these requirements the demo-model needs functions. Every functions will be thought of and the group used it in a morphological overview. On the basis of the morphological overview there will be concepts made and thereafter the final phase will the final design comes out.

Now the final phase is started, calculations will be made and everything will be designed. SolidWorks 2017 will be the 3D-program that the group will use to design the product. After the designing part the whole product will be built up for real. When the components are defined, then the group could start with the programming part, electrical part, monitoring and controlling part. Everyone has their own tasks, but you always ask someone for help if there are problems.

The group will be keeping contact with the client, this to keep him informed of the status of the project, but also to always consult with him if this is what he wants. Small adjustments in the meantime will result in less frustration than at the end a disgruntled customer or very large/important adjustments. As result of these thoughts the group and client planned a meeting.

When components are done and the client confirmed and approved these components, they will be ordered. The group have to keep in mind what the delivery time will be, because it could delay the actually building of the system.

The Zeiler method only looks at the theoretical part of a project, but the group will also build up the system and it has to work in the end.

The realizing of the system is also important part of the project. The group need to build it up like they designed it.

### 3. Designing

In this chapter the complete designing part is explained. The chapter will follow the steps the project group followed, starting with a research followed with the morphological overview then going on with some concept, component selection and the 3D model.

#### 3.1 Research

To make a good product there has to be a good research. The research was focused on the green source solution what is explained in chapter 1, transportation, water storage, field assembling, water temperature, piping, number of taps and fixing all the components.

With the knowledge of the green source solution the project group selected roughly the components for the demonstration model. The selected components were a membrane filter, UV-filter, activated carbon filter, tap and a clean water tank. These components were selected because the demonstration model has to explain the real situation and in the real situation these components are also used. On this moment trailers like Figure 7 are mostly used for demonstration purpose.



Figure 7 – Demonstration model trailer

To think a little bit out of the box the project group did a research on other trailers that can be used for the demonstration model.

In the research about the water storage the project group looked at the way the water is stored now, and some other solutions.

The research also focused on a way to make a real field in our demonstration model. There were found different solutions.

In South-Africa the water temperature increases because of the ambient temperature, the project group looked for a solution for this “problem”. The solutions were, only cold water, cold and warm water tap or only a warm water tap

The most important function of the demonstration model is to show how the system works. To show how the water will flow there was a research done for different types of pipework. In the requirements it is said: “must” one tap system, “wishes” two tap systems and “could” three tap systems

To make a solid construction with all the components fits in the project group looked at different ways to fix everything.

To make sure the water what flows out of the tap is of good quality the level of UV-Filtration has to be set. There are three levels of UV-Filtration.

### 3.2 Morphological overview

The research phase is done, all the solutions found in the research are placed in the morphological overview (shown in Appendix 14. Morphological overview). All the functions are put beneath each other in rows. All the solutions are placed in the columns. Now all the possible solutions are there, the project group members made lines with solutions for the different problems. Every line will follow one solution for every function. At the end there is a path with solutions what is need to be drawn in their concept. The morphological overview is shown in Appendix 14. Morphological overview.

### 3.3 Concept

With the lines in the morphological overview all the project group members draw a few concepts. All the concepts that is been made you can find in the Appendix 9. Concepts. There will also be some explanation about the advantages and disadvantages. After the concepts where made the concepts get marks for important features. The features that have been chosen are: functionality, expected cost price, simplicity, expected setup time, rough dimensions, meet the requirements and the complete design. The sum of these mark determines the best concept. Table 2 is the grading table where you can see that concept 2 earned the most points. The table shows that all the concepts get almost the same points, so after a meeting with the client one new final concept was made. This concept came on paper because the project group saw one big agreement with all the concepts, namely that all concepts use a cart where all components fits in. The final concept what is been made is shown in Figure 8. The benefits of this concept are: small system, does not need to buy a trailer, fit through a door, shows very simple the green source solution and a fast setup time.

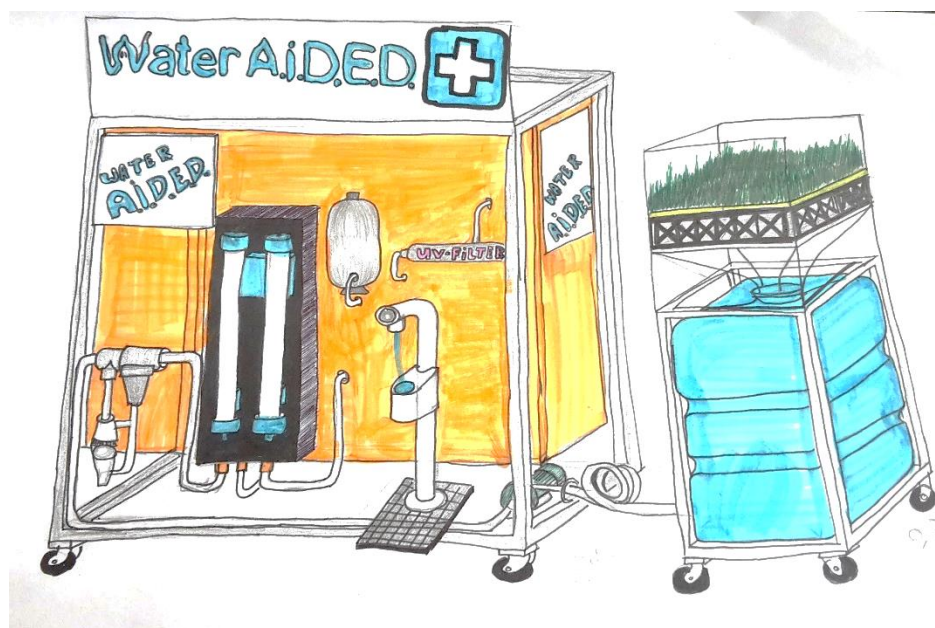

Figure 8 – Final concept

### 3.4 Piping calculation

The demonstration model used initially one tap, but maybe in the future the system will be upgraded with more taps. The following assumption was made: one tap uses 15l/min. With this assumption the project group decide to make the demonstration model ready for three taps. This means the last pump needs a capacity of at least 45 l/min.

The diameter of the pipes needs to be calculated this is done with the following formula.

$$A = Q/v$$

$$A = \text{Surface of the pipe} \quad \text{m}^2$$

$$Q = \text{Flow of the pipe} \quad \text{m}^3/\text{s}$$

$$v = \text{Speed of the water} \quad \text{m/s}$$

The project group made the assumption: Speed of the water is 1 m/s

$$Q = 45 \frac{\text{l}}{\text{min}} = 0.00075 \text{ m}^3/\text{sec}$$

$$Q = 15 \frac{\text{l}}{\text{min}} = 0.00025 \text{ m}^3/\text{sec}$$

$$v = 1 \frac{\text{m}}{\text{sec}}$$

Calculation input pump 1&2 and output pump 1

$$A = \frac{0.00075}{1} = 0.00075 \text{ m}^2 = 750 \text{ mm}^2$$

$$r = \sqrt{A/\pi}$$

$$r = \sqrt{750/\pi} = 15.45 \text{ mm}$$

Calculation output pump 2

$$A = \frac{0.00025}{1} = 0.00025 \text{ m}^2 = 250 \text{ mm}^2$$

$$r = \sqrt{A/\pi}$$

$$r = \sqrt{250/\pi} = 8.9 \text{ mm}$$

The inlet for the pump has to be a hose or pipe with a diameter van 30 mm. The outlet will be divided to three outputs for the three taps. The hose diameter for the tap has to be 18 mm.

The large hose will be 1" or 25.4 mm this is a little bit lower than the 30 mm that is been required. This decision is made because 1" is very common size. The only disadvantage is, if the 3 taps are used together the flow will decrease from 15 l/min to 10 l/min.

$$A = r^2 * \pi \quad A = 12.7^2 * \pi = 506.7 \text{ mm}^2 = 0.0005067 \text{ m}^2$$

$$Q = A * v \quad Q = 0.0005067 * 1 = 0.0005067 \frac{\text{m}^3}{\text{s}} = 30 \text{ l/min}$$

$$\frac{30 \text{ l/min}}{3} = 10 \text{ l/min}$$

### ***3.5 Component selection***

Now a design is made the components can be selected. The project group already selected some components roughly, but now it is time to make the final selection. The explanation of the system will be step by step.

#### **3.5.1 Storage skid**

1. Tank 500 litre: this tank is selected because there will not always be a water connection, so with this 500-litre tank the system can run a couple of hours. The project group made the following assumption: the system uses around 15 l/min but will not be used constantly.

#### **3.5.2 System skid**

1. Pump 1: DAB EuroInox 30/50 M. This pump is chosen because the maximum capacity is 80l/min, the pump is quiet (67 dB) and it uses only 550 Watt with 4 Ampere.
2. Membrane filter: this component was already chosen and delivered before the project started. The filter that is used is called the Lineguard.
3. Tank 325 litre: this tank is selected because this tap needs a storage with clean water so it does not have to pass all the filters before it reaches the tap. The 325 litre is quite large because pump 1 otherwise will be turned on and off constantly.
4. Pump 2: DAB Active EI25/30 M Hydrofoorpomp: This pump is selected because of its hydrophobic function, the capacity of 55 l/min, the pump is quiet (67 dB) and it uses only 370 Watt with 6.5 Ampere.
5. Activated carbon filter: after a meeting with one of our suppliers the project group decided to not use the activated carbon filter. This decision was made because it will take too much space. For the demonstration model there is still one filter placed but this one is not connected.
6. UV filter: Van Remmen V120: This component is delivered by one of our suppliers. The Van Remmen company is already a supplier of the Green Source project. In consideration with the company the demonstration model uses the V120 UV-filter.
7. Tap: Join-the-pipe bar tap: this supplier is already a supplier of the Green Source solution, that is why the demonstration model also uses a Join-the-pipe tap system.
8. Monitoring screen: Iiyama G-Master G2530 HSU-B1: this monitor is selected because of its good price and perfect dimensions. The screen is used to show information about the project.

### ***3.6 3D-model***

After the final concept was made, the components were selected the final 3D model has been made.

The designing part started with making the framework. The client set in the requirement that the final model has to be made of the Bosch Rexroth aluminium profiles. The frame looked like Figure 9 at the end. All the beams are connected with each other therefore corners where used. These corners where specially designed for these beams. During the designing process there were placed corners in every corner during the assembly the project group came to the collusion this is way too much. So, a lot of these corners where removed. The final design was changed a little bit to make it more interactive for the “visitors”. The bottom is calculated to make sure it will not bend too far. Further there are placed extra beams to mount all the components.

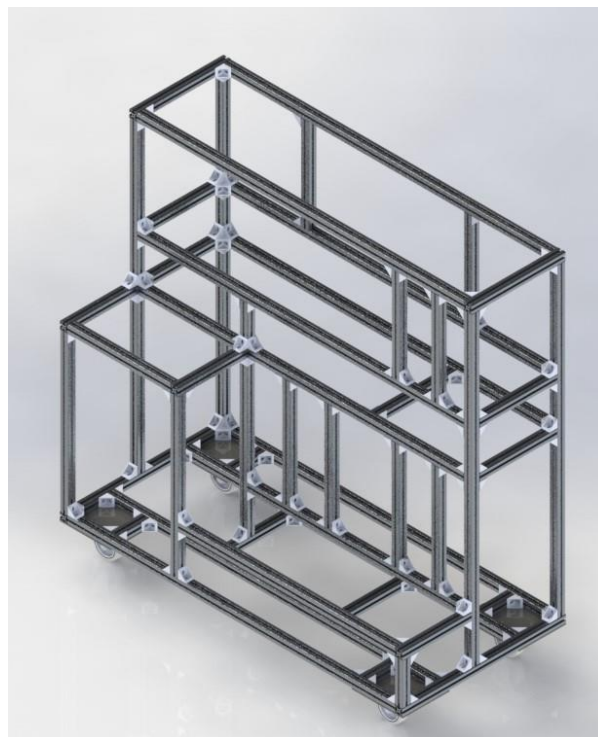

**Figure 9 – Frame**

In Figure 10 is the complete system shown without the plates. As shown all components are mounted to the beams. At the front on the bottom there is space for all the piping. Also, above the pump there is space for the piping and the electrical cabinet.

Next to the tap there is space to put a laptop or some other stuff, to come to this place there is placed a door at the back.

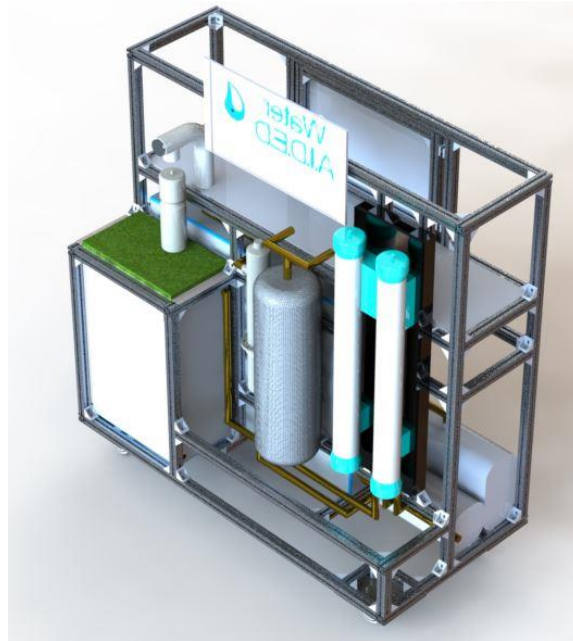

Figure 10 – Frame with components

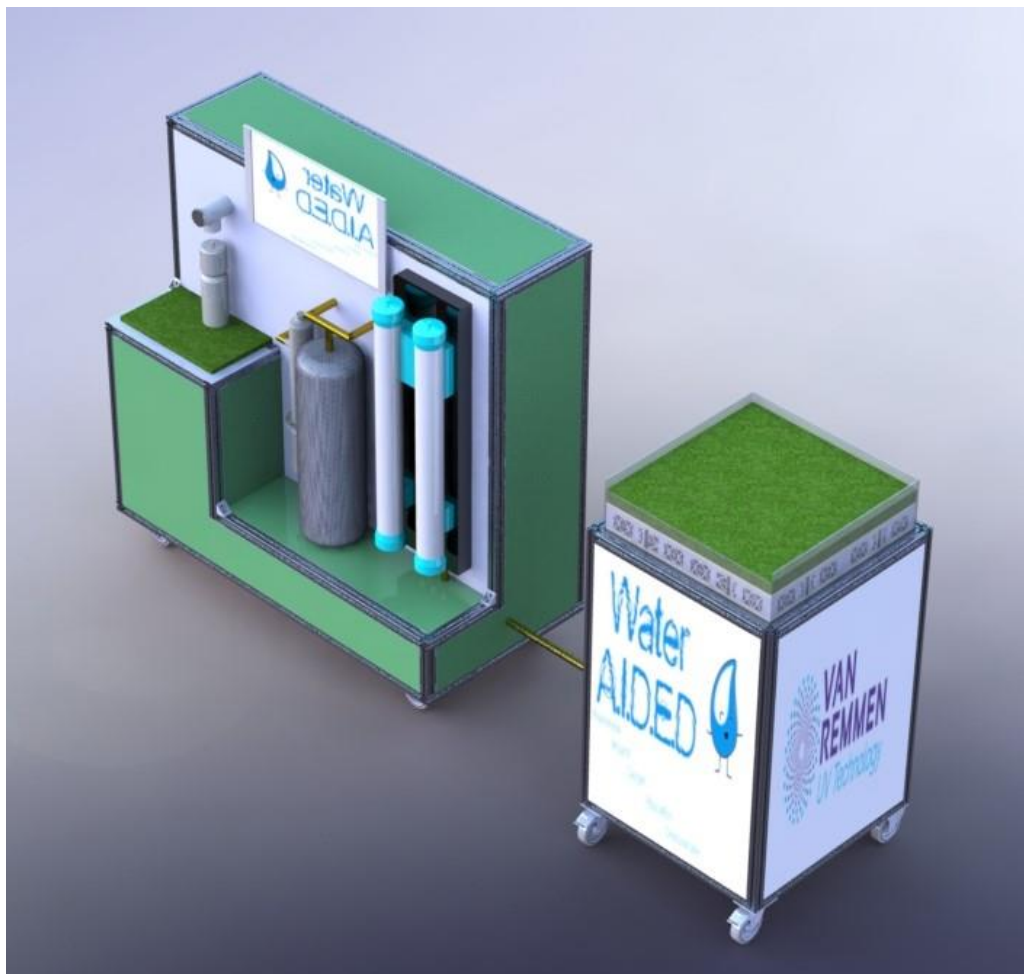

Figure 11 – Final Render



The final system looked like Figure 11. This system consists of a storage skid where is placed a large storage covered with plates on the side. On these plates are shown the partners and suppliers of the project. On top of the storage there is placed the crate and some grass to show the green source solution. The storage skid is connected to the system skid with a hose. The water is pumped out of the storage skid to the system skid. The pump pumps the water through the Lineguard into the clean water tank. This process will start and stop automatically and is set by the level of the clean water tank.

When the tap is activated the water will come out and the pressure will decrease. By the pressure drop the pump will turn on and will pump the water out of the clean water storage trough the UV-Filter towards the tap. When the water in the clean water storage is one used for a set time the water will circulate, this happens automatically when the small loop valve is opening and the pressure is decreasing again. The pump will go on and pump the water through the UV-Filter into the clean water tank.

### 3.7 Frame calculations

To make sure the frame is strong enough the bottom is calculated. The bottom exists out of 4 beams on the length direction and 2 in the depth direction. Between the 4 beams in the length direction there are 4 beams to connect everything and to make sure it is sturdy.

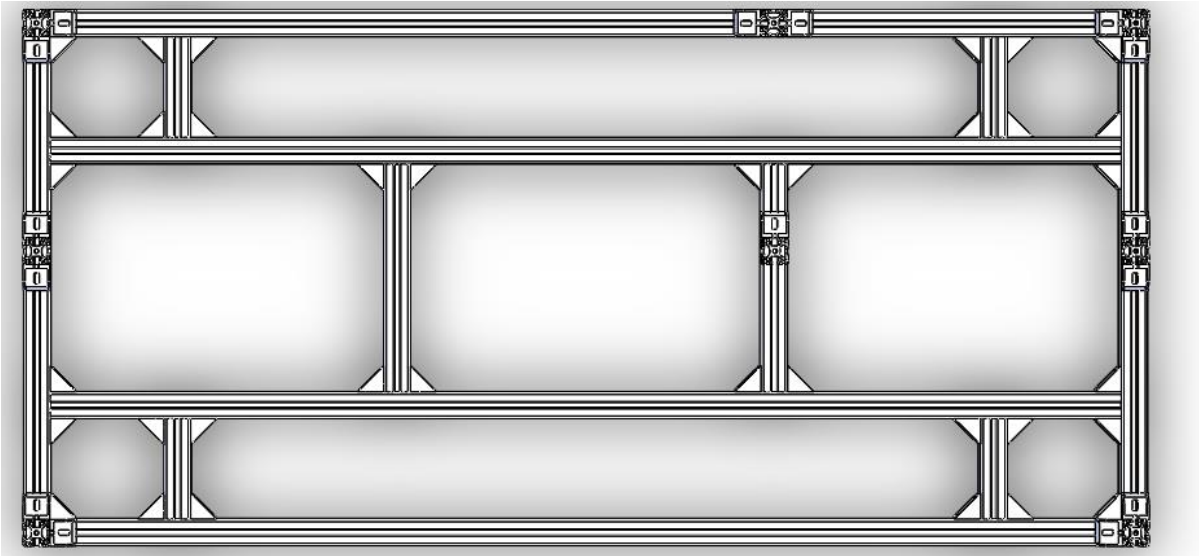

Figure 12 – Bottom frame

The beam on the bottom in Figure 12 is calculated because it is carrying the most weight. This beam is carrying the clean water storage, the pumps, and a part of the complete system.

For the calculation an assumption was made:

The weight of the complete system is 400 kg (Empty) divided by 4 beams is 100 kg for every beam.

The pumps will be in total 50 kg

The water in the clean water tank will be 325 kg. The tank rest on 2 beams so the weight will be divided.

With the weights given the free body sketch is made and looks like Figure 13.

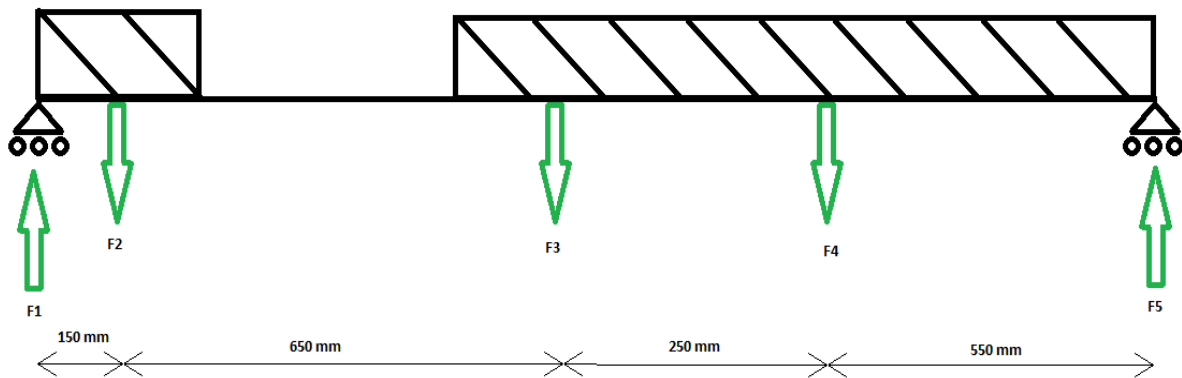

Figure 13 - Free body sketch

$$F2 = 500N = \text{Motor weight}$$

$$F3 = 1000 N = \text{Total weight of the system}$$

$$F4 = 1625 N = \text{Weigth of the water}$$

$$F1 * 1600 - F2 * 1450 - F3 * 800 - F4 * 550 = 0$$

$$F1 = \frac{500 * 1450 + 1000 * 800 + 1625 * 550}{1600} = 1511.7 N$$

$$F1 - F2 - F3 - F4 + F5 = 0$$

$$F5 = F2 + F3 + F4 - F1 = 500 + 1000 + 1625 - 1511.7 = 1613.3N$$

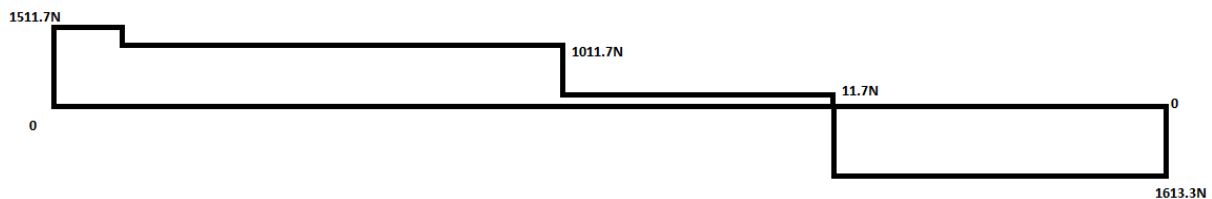

Figure 14 - D-line

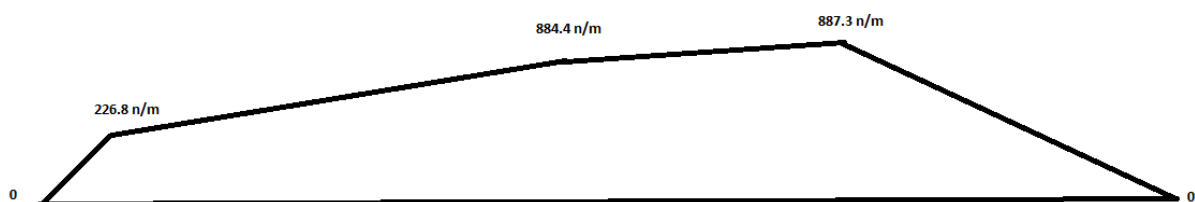

Figure 15 - M-line

To calculate the deflection the information of the beams need to be used. The information what is given is:

- Moment of inertia  $I_x = 90000 \text{ mm}^4$  (I)
  - Moment of inertia  $I_y = 90000 \text{ mm}^4$  (I)
  - Section modulus  $W_x = 4500 \text{ mm}^3$
  - Section modulus  $W_y = 4500 \text{ mm}^3$
  - Modulus of elasticity  $= 70000 \text{ n/mm}^2$  (E)
- (Rexroth Bosch Group, 2018)

First there has to be calculated one final force.

$$P = \frac{M * L}{a * b}$$

$P = \text{final force}$

$M = \text{maximum moment}$

$a = \text{distance from left side to force}$

$b = \text{distance from right side to force}$

$$P = \frac{877.3 * 1.6}{1.05 * 0.55} = 2430.6 \text{ N}$$

To calculate the deflection the following formula is used:

$$f = \frac{5 * P * L^2}{48 * E * I}$$

$$f = \frac{5 * 2430.6 * 1600^2}{48 * 70000 * 90000} = 0.1 \text{ mm}$$

So, the maximum deflection will be 0.1 mm.

### P&ID

In Appendix 11. P&ID you can find the complete piping and instrumentation diagram (P&ID). The following section gives a brief explanation regarding the operation of this P&ID with the help of parts of the P&ID.

The P&ID starts in the lower left corner in the light blue box, see Figure 16. Here you can see the dirty water skid with the artificial grass on top. Above this grass is the symbol for the irrigation of the field and a possible extra connection to irrigate it artificially. A level transmitter is connected to the dirty water tank. This level transmitter gives information to the PLC.

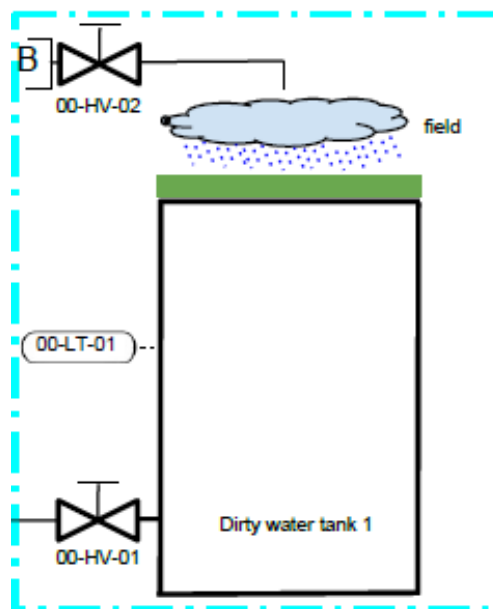
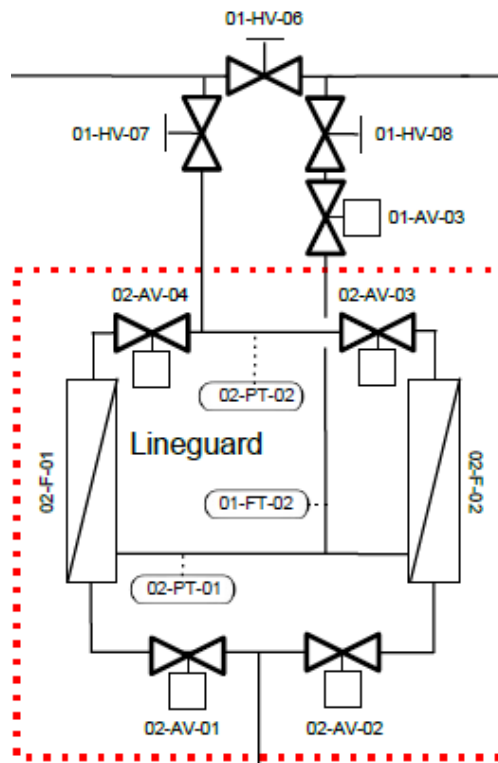

Figure 16 – P&ID part dirty water tank



**Figure 17 – P&ID part lineguard**

Then a pump ensures that the water stops by the lineguard. The lineguard system is shown above in a red square, see Figure 17. In this part of the system there are a lot of valves. These valves ensure that the system can be disconnected and the various functions of the system can work. The lineguard has two main functions, a normal function where water is filtered and one in which the filters of the lineguard are rinsed by reversing the flow of the water. The different sensors ensure that there is enough information to see whether the filter should be backwashed or completely replaced.

The rest of the system contains more valves and sensors but also a hydrophore pump. This pump ensures that the system is always on pressure. After this hydrophore pump the water flows through a UV filter system. This UV filter system guarantees that there are no bacteria, parasites and viruses left in the water. Finally, the water flows to and through the water tap.

## 4. Control system

A controlling part of a system is a very important part because this controlling part will manage, command, direct or regulates the behaviour of the system. The group want that the system can run on his own and when there is something wrong that the system gives a warning on the screen.

The group had a Siemens LOGO controlling system, as result of this the group also has to make the programming in the software the Siemens LOGO can understand, this will be "LOGO! Soft Comfort".

However, the group know this, there are a few steps they had to do before they can build up the program.

As the reader can see in the P&ID (Appendix 11. P&ID), there is a fixed path the water will follow through the system. As result of that there will be a program that manage the water to follow this path.

What is expected from the controlling system?

The program has to:

- give a warning when there is too little water in the dirty water tank.
- gives a warning if there is too much water in the dirty water tank.
- start pump 1 if there is too little water in the clean water tank.
- stop pump 1 if there is too much water in the clean water tank.
- start the backwash when needed.
- start small-loop when needed.
- manage automatic valves
- do not manage pump 2 (hydrophore pump, this manage itself)

To manage, command, direct or regulates everything of the system they need inputs and outputs of sensors. These sensors will give signals and with these signals there has to happen something.

The group first picked up every point of the expectations and does research what inputs this point need. When they write them down among each other, they had a start of a SFC.

An SFC is an abbreviation of Sequential Function Chart and can be used to program a system.

In an SFC steps and conditions will be shown. The conditions will be met before the system can proceed to the next step. On a step there will be an action connected, by a step will something happen in the system, maybe start/stop a pump or switch a valve.

To see what the SFCs are like, see Appendix 13. SFC.

Now every step and condition are defined, the SFCs are done and the group could start with the "LOGO! Soft Comfort" program. The result of these programs and explanations are in Appendix 8. Siemens Logo! Program.

## 5. Monitoring system

### 5.1 Introduction

The demonstration model is fitted with a monitoring system. This system has to display important values about pressure, capacity, etc. Comparable with the design of the complete system, we are going to design the monitoring system with the Zeiler method.

### 5.2 Problem defining

As seen in Figure 18 the problem is divided into five main parts. Sensors, data sending, data processing, warning and the user interface. With the help of the morphological overview (Figure 18) the project group created

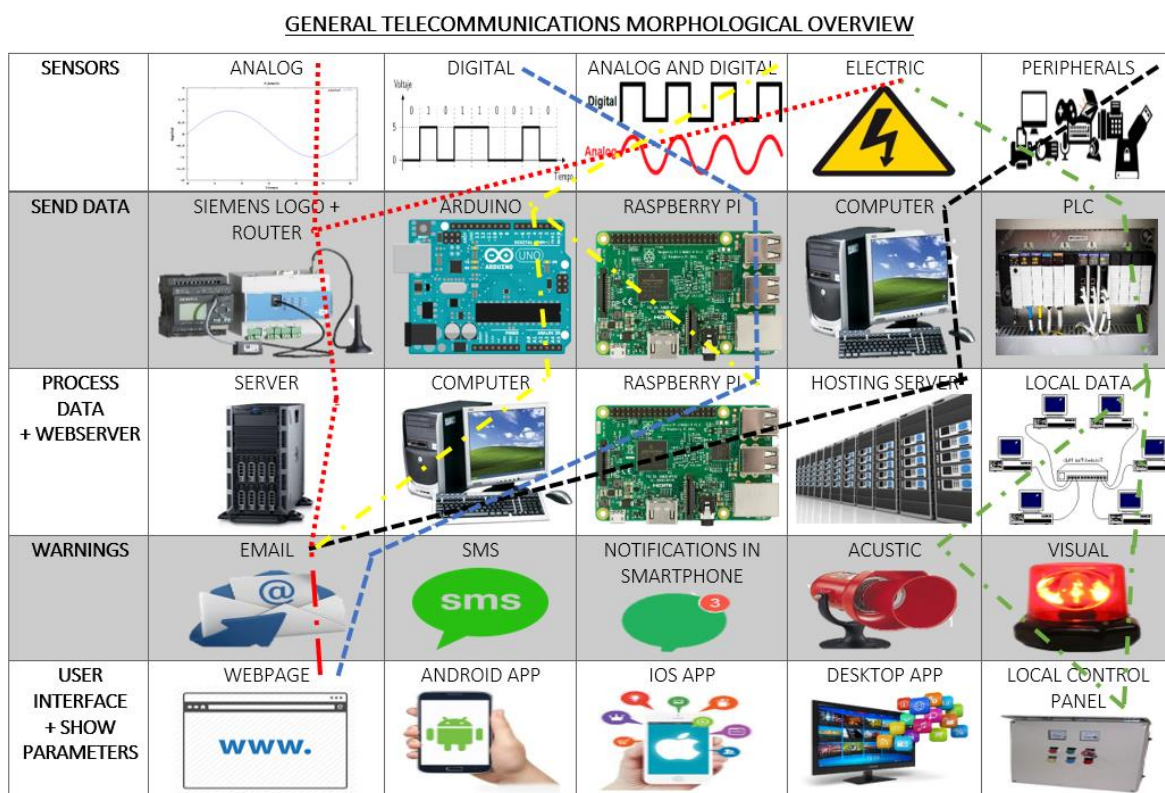

Figure 18 – Morphological overview monitoring part

### 5.3 Determining method phase

#### 1<sup>th</sup> concept

Analog or electric sensors + Siemens Logo! and router + server + email + webpage

The advantages of this combinations of options are that the Siemens Logo! is oriented for industrial work, so it is very resistant. It can be used for electrical or industrial engineers without know how to program. Also, they can use sensors with different technologies combined and has a very low failure probability for using industrial oriented machines.

The disadvantages of this system, first the Siemens Logo! has a proprietary and closed software so it is impossible to modified for the client requirements. The Siemens Logo! itself do

not have the intelligence require for work with the raw data and for this we need to connect to a server that is very expensive and big. Also, then there is a need for extra devices to send the information in the internet like a Core router. This system in general is not easy to work with, because it does not have a friendly user interface and is not available for the public, which means the people that are not familiarized with electric diagrams are not able to use, so it is not suitable for development countries. Moreover, the team don not have the knowledge of electricity and plc. The total cost of this system is very high, around 30 times more than other alternatives so the relationship between cost and functionality is very low. Finally, this whole system is very big, so it needs a lot of space to store.

## **2<sup>th</sup> concept**

Digital sensor + Raspberry PI + email + webpage (extra android app or iOS app)

The advantages of this combinations of options are that the Raspberry Pi has infinitive options and can be upgrade later with more functionalities very easily. It very widely uses in project like that, so it has a lot of options and software specifically created, with a big developer community behind, uses the technologies and protocols recently call IoT (Internet of things) so in the future is possible to add more functionality in this directions like cellular connections to send the information in remotes places. This combination has enough power to work with all the raw data that the sensors recollect and is have intelligence to interprets this data and show the state of the system in real time without the delay to process this data in a different system. The Raspberry Pi has wireless technologies built in in order to transfer the data over the internet world wide without the need of another expensive and big equipment, like a server or a computer. This tiny computer uses an open source operating system and software so we can adapt it to the necessity of our client. For that reason, too, we can create a very simple to uses graphical user interface which any person without any previous knowledge will be able to use it. In addition is also possible to build an app for any smartphone to monitor the system, that is very suitable for development countries because the access to a smartphone is more normal. To modify the working program, it can be done directly without the need of a computer so is possible to repair in the moment. This whole system is very cheap and small, so can be installed without a big investments and places anywhere. At least it can be uses for educational purposes because if you have a very friendly-to-use interface, it can be show to children or people that are learning to see the parameters and the working of the system in real time.

The disadvantages of this system are that to create at the first the program ant the interface you need to have previous knowledge of how to do it and how to code. The GPIO (General Purpose Input Output) only works with digital sensors so it is not possible to connect analogic sensors without a conversion before, and also the Raspberry Pi has a reduce number of ports, but it can be upgradable. The input voltage that support is only 3,3V so for many sensors is necessary to build a voltage divider with some resistors but is not very complicated.

## **3<sup>th</sup> concept**

Analog and digital sensors + Arduino + Raspberry PI + email + webpage

Is one of the wider options because we have a very variety of sensors to work with. But also, we have more difficult and redundancy in the system because we work at the same time with

analogy and digital data. And the conversion that are made are not very accurate and has a significant delay. And we have to interconnect also the Arduino with raspberry pi, with more system we have more failure possibility.

#### 4<sup>th</sup> concept

Electric sensors + PLC + local data + visual and acoustic + local control panel

Is the most limited option because is only works in a local term, that is to say you can only be monitoring the system if you are in the same room that your system. But is have the advantage that like it only work in a local term is simpler to build.

#### 5<sup>th</sup> concept

Peripherals sensors + computer + hosting server + email +webpage

This option is the simplest one, is uses material that are available everywhere, like a computer, some sensors connect via USB. But also, is uses proprietaries technologies so you don not have much options to modify the system for the necessity of the client. And the sensors that are available with the USB connections is very limited only temperature and humidity and we need more options to be able to be monitoring the entire system.

### 5.4 Selection phase

To make everything clearer we are going to make a table assign. Each function receives an importance and evaluate every way in order (from the best “5” to the lost “1”) and see quantitative which solutions is the more appropriate for our project.

Functions	Importance	1 th way	2th way	3th way	4th way	5th way
Sensors	2	4	3	5	2	1
Send Data	4	2	5	4	1	3
Process Data + Webservice	4	3	5	4	1	3
Warnings	1	3	4	5	1	2
User interface + show parameters	4	2	5	4	1	3
<u>Total</u>	<u>15*5 = 75</u>	<u>39</u>	<u>70</u>	<u>63</u>	<u>17</u>	<u>37</u>

**Table 1 – Multicriteria analysis**

To conclude the 2th way is the more appropriate solution for our project for these reasons we are going to incorporate to the final concept.

The main objective of this project is to make a demonstration unit to demonstrate the Green Source solution that is being applied with great success in South Africa, more than 8 installed systems. But one of the implicit objectives is to make people aware of the global shortage of drinking water and that it is necessary to find solutions for this great global problem.

And one of the great things is education is the demonstration, people learn by seeing and the best way to make people aware, as a saying says a picture is worth a thousand words. And in



a system as complex as this and with a multitude of parties, the only way to demonstrate how it works is to monitor the system completely so that it can be shown to the public.

For all the here exposed one of the points of project is to monitor the correct operation of the system, by means of a series of protocols and systems that allow to know at all times that the system is working well and all this information can be shown to the public so that it understands How our water filtration system works

The monitoring system is based on Internet of the Things (IOT), the system is composed of a series of sensors connected to each other and connected to the Raspberry Pi, the brain of our system. The Raspberry Pi connects our sensors through different protocols and thus can be accessed from outside the system to be accessible even when away from the system.

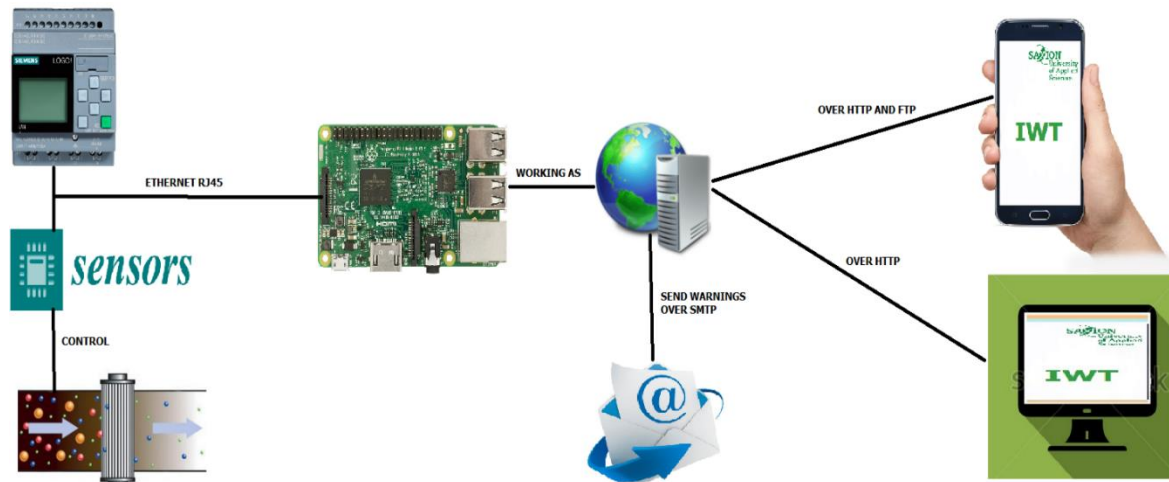

Figure 19 – Monitoring System

In addition, this monitoring system can be extended to systems in South Africa so that technicians can review the system from a distance and discover any problem or breakdown at the time can prevent dependent populations from running out of water as it is a fundamental good. The system works with notifications based on SMTP (email) autonomously when it detects that the system does not work normally.

### 5.5 Design phase

The system is created under the Windows IOT platform, using several of the developer tools to simplify the system and allow the system to be expanded by the following groups. The interface is created using UWP (Universal Windows Platform) using proprietary code and using C #, to create the executable program in Windows. The monitoring of the sensors and inter-connection is compiled under the Python language.

The components used in this system are the following:

- Raspberry Pi
- Power Supply 5V
- Raspberry Pi Expansion GPIO Module
- Sensor DS18B20 (temperature)
- 3 x Sensor HC-SR04 (capacity in the tank)
- Sensor YF-S201 (water flow)

- 2 x 4.7K Ohm resistor
- 2x 10K Ohm resistor
- 330 Ohm resistor
- 470 Ohm resistor

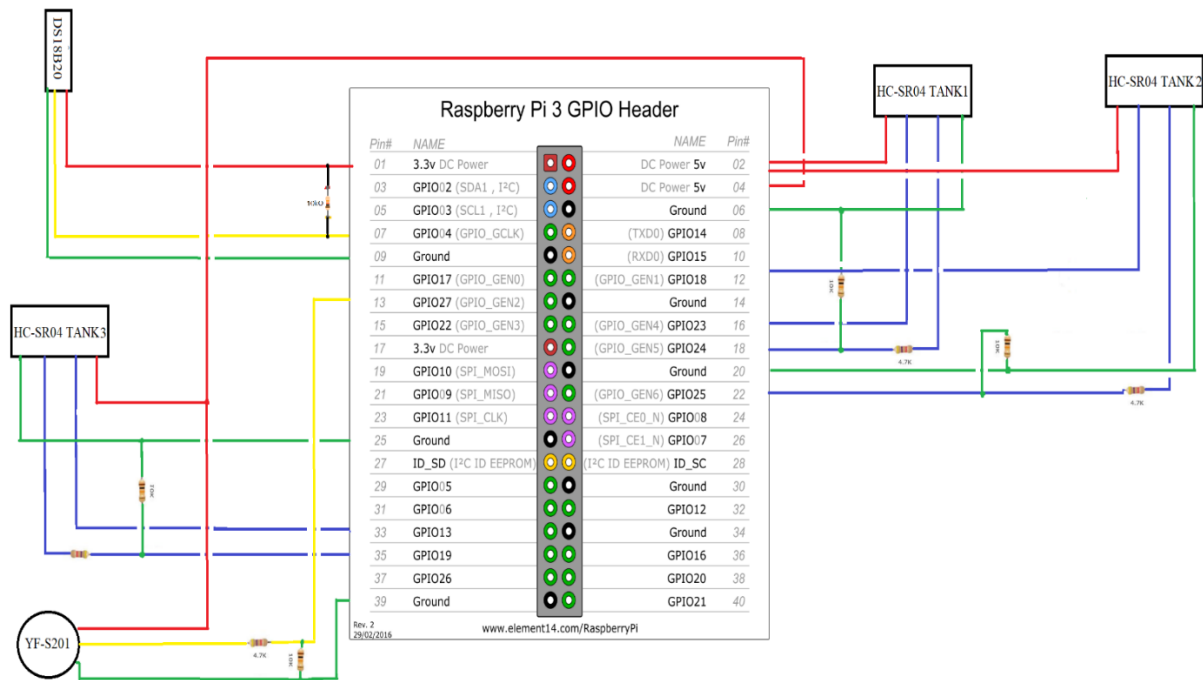

Figure 20 – Connections Raspberry Pi

The Components are connected to the general ports of the Raspberry Pi GPIO (General Port Input Output) using resistors as current dividers as follows:

The graphic interface is built using the principle of simplicity to make it as easy to use as possible, it is like the interface that any smartphone could have, with its icons (buttons) that allow different screens not only to show the system parameters in real time but also to inform the system and demonstrate how it works, that is, we use the interface with an educational function explained each part of the system individually and adding the P&ID diagrams of the system. The code of the monitoring system is explained in appendix 1.



**Figure 21 – Monitoring App Water A.I.D.E.D.**

In addition to the interface, the monitoring system is also composed of a web page (<https://wateraided.wixsite.com/website>) and a mobile platform application (Android) to monitor the system from other computers and also with a purpose educational and that in developing countries is much more widespread the use of the smartphone than the computer and is much more accessible and convenient to take anywhere. The web page is created using the HTTP and PHP language for the running scripts and the Android application was created using Java.

## 6. Discussion

This chapter will explain in detail about the choices in the different phases of this project. The group thought in detail about all the options and chose from their point of view and data the best options. There will also be a critical look at the whole process.

### *6.1 Demonstration model*

At first the project had different options on the table, the client had as requirement that we worked further on the work of previous groups and Greensource, we reduce the main system or create one by designing it from scratch. The group chose the last option for many reasons, but the most important thing is for freedom and range of motion, if you start from scratch to find a more creative and simple solution that if you go on a current prototype.

The system had certain requirements that were fixed such as a water filtration system, a tap etc. The design process began with studying in detail the system installed in South Africa and drawing concepts from the different functions that have to be installed on our system. The first concepts included a frame with all internal components but a trailer had been chosen to impose a soccer field. This turned out to be too big. To mature the ideas there were more requirements added, like a removable field, expandable field, compatible with standard doors etc. In this way we were discarding options, in the end the final decision was between four options and assigned values to each requirement.

When the concept was sketched the next step was to design it with 3D editing software, the design was improved to use the minimum number of parts to give more robustness and usability to the system and to accommodate all the necessary components. So, the final system design was based on two fundamental pillars usability and functionality.

Although we could have done things better. In the demonstration model there is just enough space for pipes and fittings. some corners in the pipe are on the tight side. Nevertheless, this was calculated and approved during the design process.

### *6.2 Components*

For the choice of components, the project team had to be aware that there were certain parts that were fixed by customer requirement or because they are essential for a water filtration system. Both Lineguard and the UV filter were fixed components, water tanks were also required. The capacity of the of the complete system was calculated, this was performed by means of a simple mathematical formula. The dirty water tank had to be capable to collect all the waste water of a day at a fair or festival. The team had taken into account that the maximum system flow is 60 l/min, and this could last about 8 hours, in this way the system need a minimum capacity of 500 litres. There are two different pumps, one operating normally on the system, this was chosen for its power and noise level. The other pump is a hydrophobic pump and was chosen to monitor the pressure and be checked by a plc. It is responsible for maintaining the pressure automatically. Other basic components were chosen to be water-resistant, and their properties easily expandable. This is to make it easier for the following groups and for system when the functionality grows.

Regarding the components the project group could not do much differently than planned. Chances are that future groups do not like the choices of the components, but the project group considered all the properties and chose these components.

The electrical design, the installation technology part, actually took too much time. There are many rules and standards that must be dealt with. As a result, much valuable time has been lost.

### ***6.3 Control and monitoring system***

For the control system the project team had to start with the existing design of the previous group, the previous group used the Siemens Logo! as logic and control unit. From the outset we wanted to implement a more visual system for one simple reason the system his main purpose, serve as sample unit in fair and festivals and therefore it is imperative that people who are not expert in the system are able to know and to see without any previous knowledge whether the system is working perfectly and what the values are. The group decided to separate the control system into two parts for several reasons, one of the reasons is to have total control of the design and creation of the system and the Siemens Logo! uses only proprietary software and certain functions.

The group searched for information and solutions and by morphological analysis chose the most appropriate solution to the system, by means scales numbers, establishing a weighting functions according to their importance. Finally, the monitoring system was Raspberry Pi with digital sensors (working at 5V).

For choice of sensors we follow the same principle, we choose the smallest possible and to make the system easily portable and removable simpler sensors. Finally, we select the interface for Visual Studio IOT program and Windows operating system to provide a more visual and easily extensible environment to other systems, such as mobile computers etc.

Unfortunately, the monitoring and control system was not complete during this project. During the smart solution festival, the project team was able to create an emergency solution for the monitoring system, although this solution is not a permanent solution. By changing the planning, we might have been able to create a better solution.

Concerning the control system, the project team missed a lot of experience and expertise. It took a lot of time to design and think through the system.

## 7. Conclusion

Based on the previous chapters and the experiences of the various project members, we have reached the following conclusions. First the technical part of the project is dealt with, then working in a group is evaluated.

- Better and clearer consultation with stakeholders regarding technical support and orders.
- Better inventory with regard to the duration of different processes. For example, order processes, development processes and so on.
- Probably it would have been better to start working on the PLC later on, as even the electrical part is not finished.

Technically, a working product has been delivered. The product has many possibilities for further development and revisions.

With regard to collaboration and cooperation in the group, sometimes it was a bit difficult but in general the cooperation was sufficient and the end result was satisfactorily. Below are some improvement points for the group.

- Discuss personal expectations better.
- A better inventory of personal knowledge and skills so that people can be deployed according to their ability and specialty. This also applies to determining the assignment.
- Working in a group with cultural differences turned out to be a lot harder than expected. It is difficult to compare your own expectations with those of someone with a different cultural background.

## 8. Recommendations

This recommendation will be documented to help the following upcoming 3s groups that are going to continue the same project that has been already done. First and for most these students from different streams are recommended to work on this upcoming project. The recommendations are written to the different functions of any future students.

### Electrical Engineer

Usually water Treatment systems mainly rely on Electricity. So, the reliability of the water supply depends on the reliability of electrical equipment. Electrical Engineers:

- Installations of electrical systems working with 16A and 230V within the Electrical Cabinet.
- Design and develop remote sensing devices for detecting leaks.
- Could setup a controlling system and monitoring system updates to get visibility from far distance.

### Computer science Engineer

- Develop and improve software modules relating to water utility data.
- Develop new implementations to match product specifications.
- Analyse all the problematic data sets.
- Can newly Design or improve the interface systems with more advanced parameters.

### Mechanical Engineer

Would mandatorily recommend mechanical engineer as design plays a major role in this project.

- As per the requirement of the client, it can be designed uniquely and more in a simplified way by concentrating on transportation of the whole system.
- Designing the piping and easy flow routes through water treatment plants.

### Chemical Engineer

It is must that a chemical engineer student must work with water treatment.

- They can concentrate on advanced filtration membranes, pH control, Reactive separation, toxicity control.
- Overseeing changes in the chemical treatment processes.
- They can even concentrate on designing and implementing waste water processes.
- Recommend trying river water filtration by using prefilter to avoid the large particles and activated carbon filters to remove the chemicals that gives exceptional smell or tastes to water such as hydrogen sulphide (rotten eggs smell) or chlorine.

## References

- Bekkema, B., Kalma, M., Schadenberg, B., Schigt, Y., & Whelan, S. (2017). *A-quality: A study on the improvement and awareness of drinking water in underdeveloped countries*. Enschede: Saxion.
- Food and agriculture organization of the United Nations. (2012). *Coping with water scarcity*. Rome: fao. Retrieved from <http://www.fao.org/docrep/016/i3015e/i3015e.pdf>
- Futselaar, Harry. (2018, 3 16). *International Water Technology*. Retrieved from Saxion: <https://www.saxion.nl/designentechnologie/site/over/lectoraten/internationalwaterechnology>
- Greenfield USA. (2018, 7 2). *TENCATE ACCORDER, WOVEN BASE CONSTRUCTION*. Retrieved from Greenfields: <http://www.greenfieldsusa.com/innovation/accorder-woven-base-construction/>
- GreenSource. (2016). *Project*. Retrieved from GreenSource: <http://www.greensourcenpc.co.za/#project>
- GreenSource. (2018, 3 15). *System*. Retrieved from GreenSource: <http://www.greensourcenpc.co.za>
- Jotem Waterbehandeling B.V. (2018, 7 1). *Over Jotem*. Retrieved from Jotem Waterbehandeling: <https://www.jotem.nl/over-jotem/>
- Mandela, N. R. (2003, 7 16). *Nelson Mandela*. Retrieved 3 5, 2018, from [http://db.nelsonmandela.org/speeches/pub\\_view.asp?pg=item&ItemID=NMS909&txtstr=education%20is%20the%20most%20powerful](http://db.nelsonmandela.org/speeches/pub_view.asp?pg=item&ItemID=NMS909&txtstr=education%20is%20the%20most%20powerful)
- Mmapula. (2018, 3 16). *About Mmapula Community Development*. Retrieved from Mmapula: <http://www.mmapula.co.za/about-us.html>
- Mohsenin, A. (2016, 07 11). *Is wasting water actually bad for the environment?* Retrieved from Quora: <https://www.quora.com/Is-wasting-water-actually-bad-for-the-environment-If-all-the-water-we-use-just-gets-recycled-anyway-what%E2%80%99s-the-point-of-not-keeping-the-faucet-running-when-brushing-your-teeth-or-taking-a-longer-shower-other-than-the-effects->
- Pentair. (2018, 3 16). *CORPORATE SOCIAL RESPONSIBILITY*. Retrieved from Pentair: <https://www.pentair.com/en/about-us/corporate-social-responsibility>
- Rexroth Bosch Group. (2018, 7 6). *Documentation & Resources*. Retrieved from AluminumStructuralFraming: [http://www.boschrexroth.ch/country\\_units/america/united\\_states/en/Documentation\\_and\\_Resources/a\\_downloads/AluminumStructuralFraming\\_Catalog.pdf](http://www.boschrexroth.ch/country_units/america/united_states/en/Documentation_and_Resources/a_downloads/AluminumStructuralFraming_Catalog.pdf)
- Ten Cate. (2018, 3 16). *Ten Cate Field in a box tm*. Retrieved from Ten Cate: <http://direct.tencate.com/news/2015/tencate-field-in-a-box-for-community-empowerment-and-sustainable-development.aspx>
- TenCate Grass. (2018, 7 2). *Synthetic Turf Systems and Components*. Retrieved from TenCate Grass: <https://www.tencategrass.com/emea-en/>
- The Water Project. (2018, 5 20). *Help Solve The Water Crisis In Africa*. Retrieved from The Water Project: <https://thewaterproject.org/how-to-give-clean-water>
- UN. (2014, 11 24). *Water Scarcity*. Retrieved from UN: <http://www.un.org/waterforlifedecade/scarcity.shtml>



- Unesco. (2012). *Managing Water Report*. Paris: United Nations Educational. Retrieved from <http://www.unesco.org/new/fileadmin/MULTIMEDIA/HQ/SC/pdf/WWDR4%20Volume%201-Managing%20Water%20under%20Uncertainty%20and%20Risk.pdf>
- VGE International BV. (n.d.). *Meest gestelde vragen over UV-C / VGE International BV*. Retrieved 3 8, 2018, from <http://vgebv.nl/veelgestelde-vragen/>
- Water For Africa. (2018, 5 20). *Our Model*. Retrieved from Water For Africa: <http://www.waterforafrica.org.uk/solutions/>
- Water Treatment Guide. (2018, 7 2). *Activated Carbon Filtration*. Retrieved from Water Treatment Guide: [http://www.watertreatmentguide.com/activated\\_carbon\\_filtration.htm](http://www.watertreatmentguide.com/activated_carbon_filtration.htm)
- Wigbers, B., Slagers, J., Hofstee, M., Slot, J., & Al Zadjali, M. (2018). *Project plan 3S Group GreenSource 3*. Enschede: Saxion.
- World Health Organization. (2017, 7 1). *WHO / Drinking-water*. Retrieved 3 5, 2018, from World Health Organization: <http://www.who.int/mediacentre/factsheets/fs391/en/>
- World Health Organization. (2018, 2 7). *Drinking water*. Retrieved from World Health Organization: <http://www.who.int/en/news-room/fact-sheets/detail/drinking-water>
- Xtreme water systems. (n.d.). *XTREME SERIES™ 8-10 GPM UV*. (Xtreme water systems) Retrieved 3 8, 2018, from <http://www.xtremewatersystems.com/whole-house-systems/xtreme-uv-systems/8-10gpm-uv>

# Appendix

## Appendix 1. Monitoring Codes

The codes of monitoring are composed of multiple programming languages, we use C#, XAML, python, java. And we use multiple template and platform to create the interface like windows form, UWP (universal windows apps) and ARM.

Firstly, the interface is created in a Windows Form and only using C#, we create the interface using the visual tools from windows in order to create the basic structure, and later we define the part and giving form in the classes.



Figure 22 – Windows Form application

This is the code that I use in the main windows form, there another 15 forms but it has a simpler code, the majority of them made with the interface editor.

```
using System;
```

```
using System.Collections.Generic;
```

```
using System.ComponentModel;
```

```
using System.Data;
```

```
using System.Drawing;
```

```
using System.Linq;
```

```
using System.Net.Mail;
```

```

using System.Text;

using System.Threading.Tasks;

using System.Windows.Forms;

namespace WindowsFormsApp1
{
    public partial class Form1 : Form
    {
        //We create all the variable that we are going to use in the entire program

        //The majoritie is for the email server (smtp)

        SmtplibClient SmtplibServer;

        MailAddress from;

        MailAddress to;

        MailMessage message;

        Attachment attachment;

        Boolean dentro = true;

        string StartText;

        public Form1()
        {
            //we initialize all the graphical component

            InitializeComponent();

            textBox1.Text = "54 l/min";

            textBox2.Text = "5 bar";

            textBox3.Text = "22 °C";

            textBox4.Text = "300l";

            textBox5.Text = "35l";

            textBox6.Text = "20l";

            richTextBox1.SelectionAlignment = HorizontalAlignment.Center;
        }
    }
}

```

```

// We establish the initial text that is going to display and we add the hour when the system is started.

StartText = "The system is working well " + "\n"+
    "Start at " + DateTime.Now.ToString("h:mm:ss tt") + DateTime.Now.ToString("dd/MM/yyyy");

richTextBox1.Text = StartText;

}

private void Form1_Load(object sender, EventArgs e)
{
}

private void label1_Click(object sender, EventArgs e)
{
}

private void label2_Click(object sender, EventArgs e)
{
}

private void label3_Click(object sender, EventArgs e)
{
}

private void label5_Click(object sender, EventArgs e)
{
}

private void textBox1_TextChanged(object sender, EventArgs e)
{
}

private void textBox2_TextChanged(object sender, EventArgs e)
{
}

private void textBox3_TextChanged(object sender, EventArgs e)
{
}

```

```

}

private void textBox4_TextChanged(object sender, EventArgs e)

{

}

private void textBox5_TextChanged(object sender, EventArgs e)

{

}

private void textBox6_TextChanged(object sender, EventArgs e)

{

}

private void richTextBox1_TextChanged(object sender, EventArgs e)

{

}

private void button1_Click(object sender, EventArgs e)

{

    // stablish the sender and the receiver to the email server

    message = new MailMessage();

    //reciever

    string TO = "mike.kolkman@hotmail.com";

    //sender

    string FROM = "water.aided@outlook.com";

    //sender password

    string PASSWORD = "WATERaided2018";

    //email body

    string BODY = "THIS IS A WARNING OF THE WATER AIDED SYTEM SEND IN " +
DateTime.Now.ToString("h:mm:ss tt") + DateTime.Now.ToString("dd/MM/yyyy");

    //email subject

    string SUBJECT = "WARNING WATER AIDED";

```

```

//we create a try to send the email and see if it send succesfull.

try
{
    //create a new smpt client and use outlook because our sender is an outlook account

    SmtptServer = new SmtptClient("smtp-mail.outlook.com", 587);

    //we pass the information to the a new mail adrees and add to our smtp server call message

    to = new MailAddress(TO);

    message.To.Add(to);

    from = new MailAddress(FROM);

    message.From = from;

    message.Subject = SUBJECT;

    message.Body = BODY;

    //stablish the credential to the sender, email and password

    SmtptServer.Credentials = new System.Net.NetworkCredential(FROM, PASSWORD); //Autenticación

    SmtptServer.EnableSsl = true;

    // send the message

    SmtptServer.Send(message);

    //display that the message is sent sucesfull

    richTextBox1.Text = StartText + "\n" + "The email was sent succesfull to " + TO + " in " +
    DateTime.Now.ToString("h:mm:ss tt") + DateTime.Now.ToString("dd/MM/yyyy");

}

//the cath is when the email has a problem a cannot be send

catch (Exception ex)
{
    // display that the email cannot be send

    richTextBox1.Text = StartText + "The email cannot be send due to an external error";

}

}

private void button2_Click(object sender, EventArgs e)

```

```

{
    Form2 desing = new Form2();

    desing.Show();
}

private void label1_Click_1(object sender, EventArgs e)
{
}

private void button3_Click(object sender, EventArgs e)
{
    //Open the webpage with the System Diagnosis that is the easy way
    System.Diagnostics.Process.Start("https://wateraided.wixsite.com/website");
}

private void chart1_Click(object sender, EventArgs e)
{
}

private void label8_Click(object sender, EventArgs e)
{
}

private void button4_Click(object sender, EventArgs e)
{
}

private void button6_Click(object sender, EventArgs e)
{
    Form8 desing1 = new Form8();

    desing1.Show();
}

private void button5_Click(object sender, EventArgs e)
{
}

```

```

Form9 desing1 = new Form9();

desing1.Show();

}

private void label12_Click(object sender, EventArgs e)

{

}

private void pictureBox2_Click(object sender, EventArgs e)

{

}

}

}

```

How is possible to see in the codes we use the class Net.Mail that has the capacity of working with emails and establish the credentials to log in the email account. Also, we establish the smtp server and the port, in our case outlook and 587. All the buttons have their own event and redirect to different forms where is the different page in our application.

All the other windows form will be available in the entire project that will be available in the official documentation from the project.

When we finished this program, and have very clear the structure of the program and all the classes and graphical elements we need, we create this program in the universal windows platforms which allow to use this program in all platforms like ARM, very important because is the platform from our system Raspberry Pi 3 B+, x86 and x64.

This new app is coded in XAML to create the visual interface, the event and the timer and in C++ and C# to create the functionality of the program. This is the code of the main page; the other 4 pages will be available in the official documentation on the project:

```

<Page
  x:Class="App1.MainPage"
  xmlns="http://schemas.microsoft.com/winfx/2006/xaml/presentation"
  xmlns:x="http://schemas.microsoft.com/winfx/2006/xaml"
  xmlns:local="using:App1"
  xmlns:d="http://schemas.microsoft.com/expression/blend/2008"
  xmlns:mc="http://schemas.openxmlformats.org/markup-compatibility/2006"
  mc:Ignorable="d"
  Background="{ThemeResource ApplicationPageBackgroundThemeBrush}">

  <Grid FocusVisualPrimaryBrush="#FF13A8A8" HorizontalAlignment="Center" Margin="0,0,0,0" VerticalAlignment="Center" Width="1956" Height="1076">
    <Grid.ColumnDefinitions>
      <ColumnDefinition Width="303*"/>
      <ColumnDefinition Width="10"/>
      <ColumnDefinition Width="332*"/>
    </Grid.ColumnDefinitions>
    <Grid.Background>

```



```

    <ImageBrush ImageSource="Assets/eau2-1.jpg"/>
</Grid.Background>
    <Button Content="" HorizontalAlignment="Left" Margin="125,909,0,0" VerticalAlignment="Top" Height="144"
Width="147" Click="Button_Click_2">
    <Button.Foreground>
        <ImageBrush ImageSource="Assets/sudafrica.png"/>
    </Button.Foreground>
    <Button.FocusVisualSecondaryBrush>
        <ImageBrush ImageSource="Assets/sudafrica.png"/>
    </Button.FocusVisualSecondaryBrush>
    <Button.FocusVisualPrimaryBrush>
        <ImageBrush ImageSource="Assets/sudafrica.png"/>
    </Button.FocusVisualPrimaryBrush>
    <Button.BorderBrush>
        <ImageBrush ImageSource="Assets/sudafrica.png"/>
    </Button.BorderBrush>
    <Button.Background>
        <ImageBrush ImageSource="Assets/sudafrica.png"/>
    </Button.Background>
</Button>
    <Image Grid.ColumnSpan="3" HorizontalAlignment="Center" Margin="0,0,0,0" VerticalAlignment="Center"/>
    <Image HorizontalAlignment="Center" Height="100" Margin="0,51,0,0" VerticalAlignment="Top" Width="580"
Grid.ColumnSpan="3">
    <Image.FocusVisualPrimaryBrush>
        <AcrylicBrush/>
    </Image.FocusVisualPrimaryBrush>
</Image>
    <TextBox HorizontalAlignment="Left" IsReadOnly="True" Margin="263,138,0,0" Text="FLOW" VerticalAlign-
ment="Top" TextChanged="TextBox_TextChanged" Foreground="#FF0020B2" TextAlignment="Center" FontSize=
"40" Width="141" RenderTransformOrigin="0.539,0.038"/>
    <TextBox x:Name="Presure" FontSize="40" TextAlignment="Center" HorizontalAlignment="Left" Mar-
gin="860,212,0,0" Text="TextBox" VerticalAlignment="Top" Height="58" Width="205" RenderTrans-
formOrigin="0.5,-0.223" TextChanged="TextBox_TextChanged_3" Grid.ColumnSpan="3"/>
    <Image HorizontalAlignment="Left" Height="100" Margin="1398,170,0,0" VerticalAlignment="Top"
Width="100" Grid.Column="2"/>
    <StackPanel HorizontalAlignment="Left" Orientation="Vertical" VerticalAlignment="Top">
    <Image>
        <Image.FocusVisualPrimaryBrush>
            <ImageBrush ImageSource="Assets/1.jpg"/>
        </Image.FocusVisualPrimaryBrush>
    </Image>

</StackPanel>
    <Image x:Name="Image1" Margin="0,0,0,0" Grid.ColumnSpan="2" HorizontalAlignment="Center" VerticalA-
lignment="Center">
    <Image.FocusVisualPrimaryBrush>
        <ImageBrush Stretch="Uniform" ImageSource="Assets/1.jpg"/>
    </Image.FocusVisualPrimaryBrush>
</Image>
    <Image HorizontalAlignment="Left" Height="100" Margin="100,407,0,0" VerticalAlignment="Top"
Width="100" Grid.Column="2">
    <Image.FocusVisualPrimaryBrush>
        <ImageBrush ImageSource="Assets/1.jpg"/>
    </Image.FocusVisualPrimaryBrush>
    <Image.FocusVisualSecondaryBrush>
        <ImageBrush ImageSource="Assets/1.jpg"/>

```

```

    </Image.FocusVisualSecondaryBrush>
</Image>
<Rectangle HorizontalAlignment="Left" Height="141" Margin="441,10,0,0" VerticalAlignment="Top"
Width="1109" IsHitTestVisible="False" Grid.ColumnSpan="3">
    <Rectangle.FocusVisualPrimaryBrush>
        <ImageBrush ImageSource="Assets/LOGO11.png"/>
    </Rectangle.FocusVisualPrimaryBrush>
    <Rectangle.Fill>
        <ImageBrush ImageSource="Assets/LOGO11.png" Stretch="Fill"/>
    </Rectangle.Fill>
    <Rectangle.Stroke>
        <ImageBrush ImageSource="Assets/LOGO11.png"/>
    </Rectangle.Stroke>
    <Rectangle.FocusVisualSecondaryBrush>
        <ImageBrush ImageSource="Assets/LOGO11.png"/>
    </Rectangle.FocusVisualSecondaryBrush>
</Rectangle>
<TextBox HorizontalAlignment="Left" FontSize="40" IsReadOnly="True" Margin="843,138,0,0"
Text="PRESSURE" VerticalAlignment="Top" TextChanged="TextBox_TextChanged" Foreground="#FF0020B2"
TextAlignment="Center" Width="231" RenderTransformOrigin="0.539,0.038" Grid.ColumnSpan="3"/>
    <TextBox HorizontalAlignment="Left" FontSize="40" IsReadOnly="True" Margin="542,136,0,0"
Text="TEMPERATURE " VerticalAlignment="Top" TextChanged="TextBox_TextChanged" Foreground="#FF0020B2"
TextAlignment="Center" Width="315" RenderTransformOrigin="0.539,0.038" Grid.Column="2"/>
    <TextBox HorizontalAlignment="Left" FontSize="40" Margin="111,308,0,0" Text="CAPACITY CLEAN TANK"
VerticalAlignment="Top" TextChanged="TextBox_TextChanged" Foreground="#FF0020B2" TextAlignment="Center"
IsReadOnly="True" Width="445" RenderTransformOrigin="0.539,0.038"/>
    <TextBox HorizontalAlignment="Left" FontSize="40" Margin="733,308,0,0" Text="CAPACITY DIRTY TANK"
VerticalAlignment="Top" TextChanged="TextBox_TextChanged" Foreground="#FF0020B2" TextAlignment="Center"
IsReadOnly="True" Width="459" RenderTransformOrigin="0.539,0.038" Grid.ColumnSpan="3"/>
    <TextBox HorizontalAlignment="Left" FontSize="40" Margin="466,308,0,0" Text="CAPACITY DIRTY TANK"
VerticalAlignment="Top" TextChanged="TextBox_TextChanged" Foreground="#FF0020B2" TextAlignment="Center"
IsReadOnly="True" Width="469" RenderTransformOrigin="0.539,0.038" Grid.Column="2"/>
    <TextBox x:Name="Temperature" FontSize="40" TextAlignment="Center" HorizontalAlignment="Left" Mar-
gin="586,207,0,0" Text="TextBox" VerticalAlignment="Top" Height="74" Width="226" RenderTrans-
formOrigin="0.5,-0.223" Grid.Column="2"/>
    <TextBox x:Name="Flow" FontSize="40" TextAlignment="Center" HorizontalAlignment="Left" Mar-
gin="237,214,0,0" Text="TextBox" VerticalAlignment="Top" Height="55" Width="193" RenderTrans-
formOrigin="0.5,-0.223" TextChanged="TextBox_TextChanged_1"/>
    <TextBox x:Name="Capacity2" FontSize="40" TextAlignment="Center" HorizontalAlignment="Left" Mar-
gin="870,407,0,0" Text="TextBox" VerticalAlignment="Top" Height="56" Width="204" RenderTrans-
formOrigin="0.5,-0.223" Grid.ColumnSpan="3"/>
    <TextBox x:Name="Capacity3" FontSize="40" TextAlignment="Center" HorizontalAlignment="Left" Mar-
gin="589,387,0,0" Text="TextBox" VerticalAlignment="Top" Height="70" Width="223" RenderTrans-
formOrigin="0.5,-0.223" Grid.Column="2"/>
    <Button Content="" HorizontalAlignment="Left" Margin="441,909,0,0" VerticalAlignment="Top" Height="157"
Width="187" Click="Button_Click_3">
        <Button.FocusVisualPrimaryBrush>
            <ImageBrush ImageSource="Assets/weblogo.png"/>
        </Button.FocusVisualPrimaryBrush>
        <Button.BorderBrush>
            <ImageBrush ImageSource="Assets/weblogo.png"/>
        </Button.BorderBrush>
        <Button.FocusVisualSecondaryBrush>
            <ImageBrush ImageSource="Assets/weblogo.png"/>
        </Button.FocusVisualSecondaryBrush>
        <Button.Background>

```

```

        <ImageBrush ImageSource="Assets/weblogo.png"/>
    </Button.Background>
</Button>
<Button Content="" HorizontalAlignment="Left" Margin="876,909,0,0" VerticalAlignment="Top" Height="157"
Width="173" Click="Button_Click_4" Grid.ColumnSpan="3">
    <Button.FocusVisualSecondaryBrush>
        <ImageBrush ImageSource="Assets/alert-triangle-512.png"/>
    </Button.FocusVisualSecondaryBrush>
    <Button.FocusVisualPrimaryBrush>
        <ImageBrush ImageSource="Assets/alert-triangle-512.png"/>
    </Button.FocusVisualPrimaryBrush>
    <Button.BorderBrush>
        <ImageBrush ImageSource="Assets/alert-triangle-512.png"/>
    </Button.BorderBrush>
    <Button.Background>
        <ImageBrush ImageSource="Assets/alert-triangle-512.png"/>
    </Button.Background>
</Button>
<Button Content="" HorizontalAlignment="Left" Margin="335,909,0,0" VerticalAlignment="Top" Height="144"
Width="192" Click="Button_Click_5" Grid.Column="2">
    <Button.FocusVisualSecondaryBrush>
        <ImageBrush ImageSource="Assets/Drawing_Tools-512.png"/>
    </Button.FocusVisualSecondaryBrush>
    <Button.FocusVisualPrimaryBrush>
        <ImageBrush ImageSource="Assets/Drawing_Tools-512.png"/>
    </Button.FocusVisualPrimaryBrush>
    <Button.BorderBrush>
        <ImageBrush ImageSource="Assets/Drawing_Tools-512.png"/>
    </Button.BorderBrush>
    <Button.Background>
        <ImageBrush ImageSource="Assets/Drawing_Tools-512.png"/>
    </Button.Background>
</Button>
<Button Content="" HorizontalAlignment="Left" Margin="773,909,0,0" VerticalAlignment="Top" Height="144"
Width="186" Click="Button_Click_6" Grid.Column="2">
    <Button.FocusVisualSecondaryBrush>
        <ImageBrush ImageSource="Assets/About_us_copy-512.png"/>
    </Button.FocusVisualSecondaryBrush>
    <Button.FocusVisualPrimaryBrush>
        <ImageBrush ImageSource="Assets/About_us_copy-512.png"/>
    </Button.FocusVisualPrimaryBrush>
    <Button.BorderBrush>
        <ImageBrush ImageSource="Assets/About_us_copy-512.png"/>
    </Button.BorderBrush>
    <Button.Background>
        <ImageBrush ImageSource="Assets/About_us_copy-512.png"/>
    </Button.Background>
</Button>
<TextBox x:Name="General0" FontSize="40" HorizontalAlignment="Left" Margin="111,506,0,0" Text="Text-
Box" VerticalAlignment="Top" Height="81" Width="551"/>
<TextBox x:Name="Capacity1" FontSize="40" TextAlignment="Center" HorizontalAlignment="Left" Mar-
gin="217,407,0,0" Text="TextBox" VerticalAlignment="Top" Height="56" Width="226" RenderTrans-
formOrigin="0.5,-0.223" TextChanged="Capacity2_Copy_TextChanged"/>
<TextBox x:Name="General1" FontSize="40" HorizontalAlignment="Left" Margin="111,587,0,0" Text="Text-
Box" VerticalAlignment="Top" Height="83" Width="551"/>

```

```

        <TextBox x:Name="General2" FontSize="40" HorizontalAlignment="Left" Margin="111,670,0,0" Text="Text-
Box" VerticalAlignment="Top" Height="72" Width="551"/>
        <TextBox x:Name="General3" FontSize="40" HorizontalAlignment="Left" Margin="111,742,0,0" Text="Text-
Box" VerticalAlignment="Top" Height="86" Width="551"/>
        <TextBlock Grid.ColumnSpan="3" FontSize="40" HorizontalAlignment="Left" Margin="843,476,0,0"
Text="ANDROID APP" TextWrapping="Wrap" VerticalAlignment="Top" RenderTransformOrigin="0.423,0.55"/>
        <Rectangle Grid.ColumnSpan="3" HorizontalAlignment="Center" Height="282" Margin="0,546,0,0" VerticalAl-
ignment="Top" Width="295" RenderTransformOrigin="0.584,0.712">
            <Rectangle.Fill>
                <ImageBrush ImageSource="Assets/DPMA1L.png"/>
            </Rectangle.Fill>
        </Rectangle>
        <Rectangle Grid.Column="2" HorizontalAlignment="Left" Height="335" Margin="299,493,0,0" VerticalAlign-
ment="Top" Width="660">
            <Rectangle.Fill>
                <ImageBrush ImageSource="Assets/ezgif.com-gif-maker (3).gif"/>
            </Rectangle.Fill>
        </Rectangle>
        <TextBlock HorizontalAlignment="Left" Margin="64,843,0,0" FontSize="40" Text="SOUTH AFRICA" TextWrap-
ping="Wrap" VerticalAlignment="Top" RenderTransformOrigin="0.412,0.883"/>
        <TextBlock HorizontalAlignment="Left" Margin="437,843,0,0" FontSize="40" Text="WEB PAGE" TextWrap-
ping="Wrap" VerticalAlignment="Top" RenderTransformOrigin="0.412,0.883" SelectionChanged="TextBlock_Selec-
tionChanged_1"/>
        <TextBlock HorizontalAlignment="Left" Margin="853,843,0,0" FontSize="40" Text="SEND ALERT" TextWrap-
ping="Wrap" VerticalAlignment="Top" RenderTransformOrigin="0.412,0.883" Grid.ColumnSpan="3"/>
        <TextBlock HorizontalAlignment="Left" Margin="384,843,0,0" FontSize="40" Text="P&ID" TextWrap-
ping="Wrap" VerticalAlignment="Top" RenderTransformOrigin="0.412,0.883" Grid.Column="2"/>

        <TextBlock HorizontalAlignment="Left" Margin="748,843,0,0" FontSize="40" Text="ABOUT US" TextWrap-
ping="Wrap" VerticalAlignment="Top" RenderTransformOrigin="0.412,0.883" Grid.Column="2" Height="56"
Width="195"/>

    </Grid>
</Page>

```

The codes for the sensors and to process the information is codes using Python and C#, this is the code for the capacity sensors, we created in a dependent class and invoke it for the main page with a constructor. This is the code:

```

using System;

using System.Diagnostics;

using System.Threading.Tasks;

using UnitsNet;

using Windows.Devices.Gpio;

namespace App1
{
    public class HCSR04
    {

```

```

private GpioController gpio = GpioController.GetDefault();

private GpioPin trig;

private GpioPin echo;

private int trig_Pin;

private int echo_Pin

static Object deviceLock = new object()

Stopwatch sw = new Stopwatch();

public int TimeoutMilliseconds { get; set; } = 20;

/// <summary>
/// Create an HCSR04 Sensor
/// </summary>
/// <param name="trig_Pin"></param>
/// <param name="echo_Pin"></param>
/// <param name="timeoutMilliseconds">defaults to 20</param>
public HCSR04(byte trig_Pin, byte echo_Pin, int timeoutMilliseconds = 20)
{
    Initialise(trig_Pin, echo_Pin, timeoutMilliseconds);
}

/// <summary>
/// Initialise ultra sonic distance sensor
/// </summary>
/// <param name="trig_Pin"></param>
/// <param name="echo_Pin"></param>
/// <param name="maxDistance">Set Ultra Sonic maximum distance to detect. This is approximate only.
Based on 34.3 cm per millisecond, 20 degrees C at sea level</param>
public HCSR04(byte trig_Pin, byte echo_Pin, Length maxDistance)
{
    int milliSeconds = (int)(maxDistance.Centimeters / 34.3 * 2);

    Initialise(trig_Pin, echo_Pin, milliSeconds);
}

```

```

}

private void Initialise(byte trig_Pin, byte echo_Pin, int timeoutMilliseconds)
{
    this.trig_Pin = trig_Pin;

    this.echo_Pin = echo_Pin;

    TimeoutMilliseconds = timeoutMilliseconds;

    trig = gpio.OpenPin(trig_Pin);

    echo = gpio.OpenPin(echo_Pin);

    trig.SetDriveMode(GpioPinDriveMode.Output);

    echo.SetDriveMode(GpioPinDriveMode.Input);

    trig.Write(GpioPinValue.Low);
}

/// <summary>

    /// Set Ultra Sonic maximum distance to detect. This is approximate only. Based on 34.3 cm per millisecond,
    20 degrees C at sea level

    /// </summary>

    /// <param name="maxDistance"></param>

    /// <returns></returns>

public Length GetDistance(Length maxDistance)
{
    int milliSeconds = (int)(maxDistance.Centimeters / 34.3 * 2);

    return GetDistance(milliSeconds);
}

public Length GetDistance()
{
    return GetDistance(TimeoutMilliseconds);
}

/// <summary>

    /// Measures distance in centimeters

```

```

/// </summary>

/// <param name="timeoutMilliseconds">20 milliseconds is enough time to measure up to 3 me-
ters</param>

/// <returns></returns>

public Length GetDistance(int timeoutMilliseconds = 20)
{
    lock (deviceLock)
    {
        //http://www.c-sharpcorner.com/UploadFile/167ad2/how-to-use-ultrasonic-sensor-hc-sr04-in-ar-
        duino/

        //http://www.modmypi.com/blog/hc-sr04-ultrasonic-range-sensor-on-the-raspberry-pi

        trig.Write(GpioPinValue.Low);           // ensure the trigger is off

        Task.Delay(TimeSpan.FromMilliseconds(1)).Wait(); // wait for the sensor to settle

        trig.Write(GpioPinValue.High);          // turn on the pulse

        Task.Delay(TimeSpan.FromMilliseconds(.01)).Wait(); // let the pulse run for 10 microseconds

        trig.Write(GpioPinValue.Low);          // turn off the pulse

        var time = PulseIn(echo, GpioPinValue.High, timeoutMilliseconds);

        // https://en.wikipedia.org/wiki/Speed_of_sound

        // speed of sound is 34300 cm per second or 34.3 cm per millisecond

        // since the sound waves traveled to the obstacle and back to the sensor

        // I am dividing by 2 to represent travel time to the obstacle

        return Length.FromCentimeters(time * 34.3 / 2.0); // at 20 degrees at sea level
    }
}

private double PulseIn(GpioPin pin, GpioPinValue value, int timeout)
{
    {
        sw.Restart();

        // Wait for pulse

```

```

while (sw.ElapsedMilliseconds < timeout && pin.Read() != value) { }

if (sw.ElapsedMilliseconds >= timeout)
{
    sw.Stop();

    return 0;
}

sw.Restart();

// Wait for pulse end

while (sw.ElapsedMilliseconds < timeout && pin.Read() == value) { }

sw.Stop();

return sw.ElapsedMilliseconds < timeout ? sw.Elapsed.TotalMilliseconds : 0;
}
}
}

```

And this is the code from the principal page where we create the instance from the sensors and calculate the liters left in the tanks with some formulas. Also here invoke the class of the sensors.

```

using System;

using System.Collections.Generic;

using System.IO;

using System.Linq;

using System.Runtime.InteropServices.WindowsRuntime;

using Windows.Foundation;

using Windows.Foundation.Collections;

using Windows.UI.Xaml;

using Windows.UI.Xaml.Controls;

using Windows.UI.Xaml.Controls.Primitives;

using Windows.UI.Xaml.Data;

```



```

using Windows.UI.Xaml.Input;

using Windows.UI.Xaml.Media;

using Windows.UI.Xaml.Navigation;

using Windows.ApplicationModel.Email;

using Windows.Devices.Gpio;

using UnitsNet;

namespace App1
{
    /// <summary>
    /// </summary>
    public sealed partial class MainPage : Page
    {
        HCSR04 sensor1 = new HCSR04(23, 24);

        HCSR04 sensor2 = new HCSR04(18, 25);

        private DispatcherTimer timer;

        double d1;

        double d2;

        public MainPage()
        {
            this.InitializeComponent();

            Temperature.Text = "25 °C";

            Temperature.IsReadOnly = true;

            Flow.Text = "20l/min";

            Flow.IsReadOnly = true;

            Pressure.Text = "3 bar";

            Pressure.IsReadOnly = true;

            Capacity1.Text = "270l";

            Capacity1.IsReadOnly = true;
        }
    }
}

```

```

Capacity2.Text = "170!";

Capacity2.IsReadOnly = true;

Capacity3.Text = "40!";

Capacity3.IsReadOnly = true;

General0.Text = "The system is working well";

General0.IsReadOnly = true;

General1.Text = "Start at " + DateTime.Now.ToString("h:mm:ss tt") +
DateTime.Now.ToString("dd/MM/yyyy");

General1.IsReadOnly = true;

General2.Text = "";

General2.IsReadOnly = true;

General3.Text = "";

General3.IsReadOnly = true;

timer = new DispatcherTimer();

timer.Interval = new TimeSpan(0, 0, 1);

timer.Tick += timer_Tick;

Length distancia = sensor1.GetDistance();

timer.Start();
}

void timer_Tick(object sender, object e)
{
    string s2 = sensor1.GetDistance().ToString();

    string s3 = sensor2.GetDistance().ToString();

    General3.Text = s2;

    General2.Text = s3;

    d1 = 104 - (5 * 3 * (sensor1.GetDistance().Centimeters / 10));

    d2 = 510 - (7.2 * 7.2 * (sensor2.GetDistance().Centimeters/10));

timer.Stop();

    timer = new DispatcherTimer();
}

```

```

timer.Interval = new TimeSpan(0, 0, 6);

timer.Tick += timer_Tick;

timer.Start();

Capacity3.Text = d1.ToString("0") + "l";

Capacity2.Text = d2.ToString("0") + "l";

}

private void Button_Click(object sender, Windows.UI.Xaml.RoutedEventArgs e)

{

    this.Frame.Navigate(typeof(BlankPage1));

}

private void TextBox_TextChanged(object sender, TextChangedEventArgs e)

{

}

private void Button_Click_1(object sender, RoutedEventArgs e)

{

    this.Frame.Navigate(typeof(BlankPage1));

}

private void Button_Click_2(object sender, RoutedEventArgs e)

{

    this.Frame.Navigate(typeof(BlankPage2));

}

private void Button_Click_3(object sender, RoutedEventArgs e)

{

ContentDialog noWifiDialog = new ContentDialog

{

    Title = "WEB PAGE",

    Content = "https://wateraided.wixsite.com/website",

    CloseButtonText = "Close"

```

```

};

noWifiDialog.ShowAsync();

string s2 = sensor1.GetDistance().ToString();

General3.Text = s2;

var uriBing = new Uri(@"https://wateraided.wixsite.com/website");

// Launch the URI

var success = Windows.System.Launcher.LaunchUriAsync(uriBing);
}

private void Button_Click_4(object sender, RoutedEventArgs e)
{
//to send the email we need be out of the sandboxof uwp

General2.Text = "The email was sent succesfull to mike.kolkman@hotmail.com";

General3.Text = " in " + DateTime.Now.ToString("h: mm: ss tt") + DateTime.Now.ToString("dd / MM / yyyy");
}

private void Button_Click_5(object sender, RoutedEventArgs e)
{
this.Frame.Navigate(typeof(BlankPage3));
}

private void Button_Click_6(object sender, RoutedEventArgs e)
{
this.Frame.Navigate(typeof(BlankPage4));
}

private void TextBox_TextChanged_1(object sender, TextChangedEventArgs e)
{
}

private void TextBox_TextChanged_2(object sender, TextChangedEventArgs e)
{
}

```

```
}  
  
private void TextBox_TextChanged_3(object sender, TextChangedEventArgs e)  
{  
}  
  
private void TextBlock_SelectionChanged(object sender, RoutedEventArgs e)  
{  
}  
  
private void RichTextBlock_SelectionChanged(object sender, RoutedEventArgs e)  
{  
}  
  
private void Capacity2_Copy_TextChanged(object sender, TextChangedEventArgs e)  
{  
}  
  
private void TextBlock_SelectionChanged_1(object sender, RoutedEventArgs e)  
{  
}  
}  
}
```

All the other uwp page will be available in the entire project that will be available in the official documentation from the project.

## Appendix 2. Webpage

The Webpage was created with HTML and PHP using the visual editor eclipse. Is available in 7 different languages: English, Dutch, German, French, Dutch, Portuguese, Spanish and Hindi. This is the link of the webpage:

<https://wateraided1.wixsite.com/website>

In order to simply for the next groups we transfer the site to a web visual editor WIX, this is the account from the site wix.com that have the property of the webpage.

Email: [water.aided@outlook.com](mailto:water.aided@outlook.com)

Password: waterAIDED

When you can enter in this site, is possible to edit and page and languages to the webpage with an easy graphical user interface.



Figure 23 – Screenshot website Water A.I.D.E.D.

### *Appendix 3. Lineguard*



**Figure 24 – Lineguard UF-100**

#### Performance:

Total Capacity: >5.000m<sup>3</sup>

Efficiency: >98%

Control unit: type CWS EC 2

Initial flow rate: 60l/min

Input data: cleaning cycle parameters

Output data: total volume, pressure drop, performance indication

#### Connections

Feed rate: 22mm, 3/4inch

#### Operating conditions

Storage temperature: Min +1 °C, Max +50 °C

Ambient temperature: min +1 °C, Max +50

Relative humidity: up to 100%

Supply voltage: 99–264vac

Power consumption during cleaning: Max 20W

Power consumption during filtering: Max 1W

Max inlet pressure: 4bar/ 58psi

## How Lineguard works

### Filtration mode

The Line Guard membrane modules contain hundreds of capillary ultrafiltration (UF) membranes. The porous walls of these hollow fibres contain billions of microscopic pores which act as an ultra-fine sieve.

The water pressure pushes water molecules and vital minerals from the inside-out through the pores of the membrane fibres, while retaining larger contaminants such as bacteria, parasites and viruses.

Automated cleaning cycles periodically flush out the contaminants retained inside the membranes. Once the Line Guard has been installed on the main water supply line, the water is filtered by the membrane modules.

### Cleaning cycles

Contaminants in the water clog the inner surface of the membranes, which affect the performance of the system. The Line Guard is equipped with a control unit that sets automated cleaning cycles so that this fouling is periodically flushed out.

There are two types of cleaning cycles:

- 1) forward flush
- 2) backwash flush

### Forward flush

In a forward flush the membranes are flushed with feed water. The feed water flows through the inner part of the membranes at a much greater speed than in the filtering mode. Because of this high flow and the resulting turbulence, the fouling on the membrane is released and discharged. The flush water is discharged to the system drain. Particles that are caught in the membrane pores are not released and can only be removed with a backwash. Please note that the backwash needs backpressure from the water line after the system for an optimal cleaning cycle.

Whenever the Line Guard discharges to an open system, like a water tank, the backwash will be not being performed at an optimal level.

### Backward flush

A backwash is performed by reversing the filtration process. Filtered water (or permeate as it is called) is flushed from the outside to the inside of the membranes. This way, particles that are caught in the

membrane pores are released and discharged. In a backwash the Line Guard uses permeate from one module to backwash the other so that the modules will not foul at the 'clean side'. The flush water is



discharged to the system.

#### Installation of the line Guard

The line Guard membrane filtration system should be installed in the main water supply line near its entry

into the building. It should be placed at any point past the main shut-off valve, before the pipes branch off

into multiple directions. This manual provides general guidelines for the installation. Please keep in mind that the installation must always comply with all local and national plumbing guidelines and should be carried out by a certified installation company.

#### Mounting the Line Guard

The Line Guard should be attached to the wall with suitable fasteners. The wall must be flat and the

material must be strong enough to support the Line Guard. To allow enough built-in space for the water pipes and for the display to be at a readable height it is recommended to mount the Line Guard at 600 mm (2 feet) above floor level. At least 100 mm (4 inches) of clear space is recommended at the top for releasing the modules.

#### Piping installation

The line Guard membrane filtration system should be placed on the main water supply line near its entry

into the building. It can be situated at any point past the main shut-off valve, but before the pipes branch off

into multiple directions. To install the line Guard, three 22 mm pipe ends must be connected. See the figure

below. An adapter 22 mm to 3/4 inch is included.

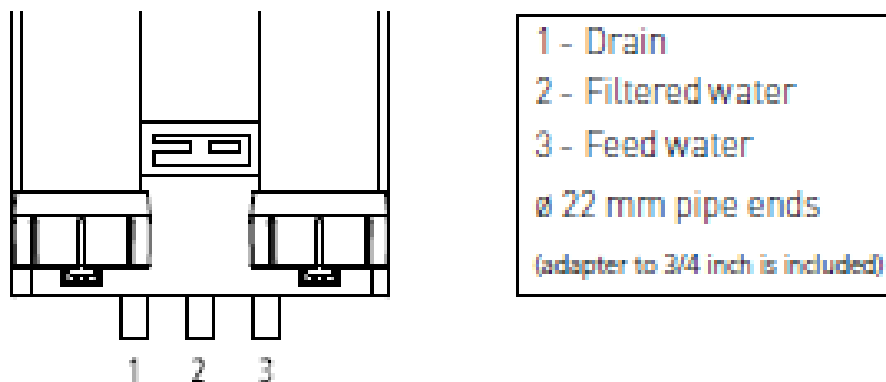

Figure 25 – Connections Lineguard

## Dimensions

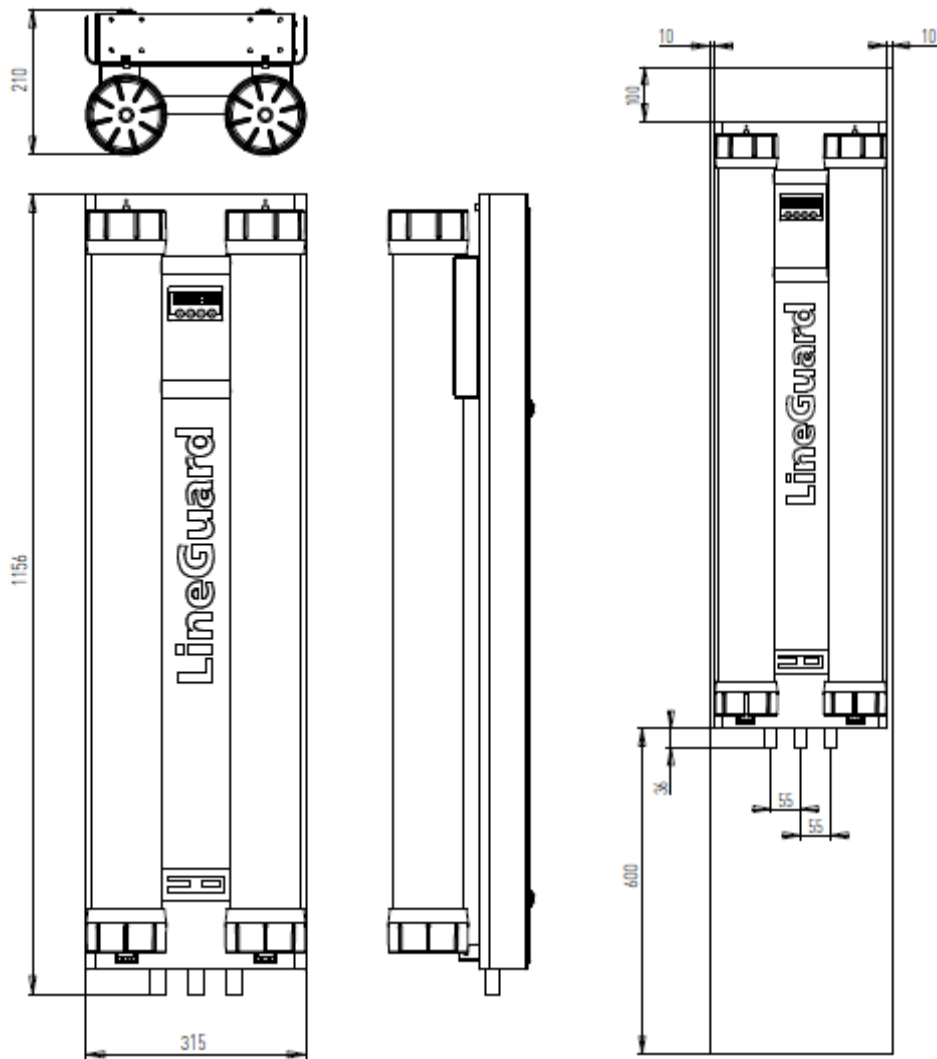

Figure 26 – Lineguard dimensions

## Dimensions

Height: 1156 mm / 45,5 inch

Width: 315 mm / 12,5 inch

Depth: 210 mm / 8,3 inch

## Clearance

Bottom: 600 mm / 2 ft

Sides: 10 mm / ½ inch

Top: 100 mm / 4 inch

## Weight

Complete: 33 kg / 73 lbs

Without modules: 21 kg / 47 lbs

## Appendix 4. UV Water filters

There are multiple ways to filter water by UV light. There are differences in the frequency of the ultraviolet light. There is UV-A, UV-B and UV-C, as you can see in Figure 27. The most used one is UV-C because this one kills the most bacterias and diseases. It is a dangerous light source; therefore, it is only used in a closed room. The levels of danger are represented in the different names of the ultraviolet light with A as the least dangerous and C as the most dangerous. (VGE International BV, sd)

Advantages of UV water filtering:

- It is very effective because it destroys 99.99% of microorganisms.
- It is Reliable- works night and day
- It is cost effective- only lamps and sleeve are replaced
- It has no disinfection by products, and it is environmentally friendly.
- UV does not alter taste, odour, colour or pH of the water
- UV does not require the addition of chemicals
- UV does not impart toxic by-products into the water
- UV systems are compact and easy to install
- UV systems require very little maintenance
- Running costs are often lower than those of a household lightbulb

Disadvantages of UV Filter.

- UV light only able to eliminate Microorganisms in water. It does not remove any other contaminants from water like heavy metals, salts
- This system requires electricity to operate it. This might not be suitable for all applications such as rural, emergency needs etc.
- UV light is only able to work if only the water is clear. If water contains floaties, then a pre-filter must be used because the UV light cannot effectively reach microorganisms.

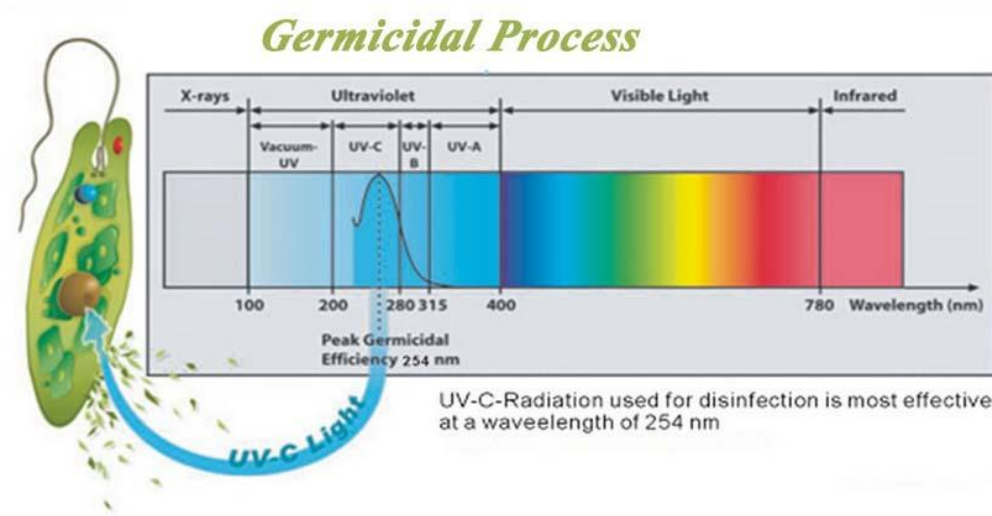

Figure 27 – UV light frequencies (Xtreme water systems, sd)

### ***Appendix 5. Activated carbon filter***

Granular activated carbon (GAC) is commonly used for removing organic constituents and residual disinfectants in water supplies. This not only improves taste and minimizes health hazards; it protects other water treatment units such as reverse osmosis membranes and ion exchange resins from possible damage due to oxidation or organic fouling. Activated carbon is a favoured water treatment technique because of its multifunctional nature and the fact that it adds nothing detrimental to the treated water.

Most activated carbons are made from raw materials such as nutshells, wood, coal and petroleum.

Typical surface area for activated carbon is approximately 1,000 square meters per gram (m<sup>2</sup>/gm). However, different raw materials produce different types of activated carbon varying in hardness, density, pore and particle sizes, surface areas, extractables, ash and ph. These differences in properties make certain carbons preferable over others in different applications.

The two principal mechanisms by which activated carbon removes contaminants from water are adsorption and catalytic reduction. Organics are removed by adsorption and residual disinfectants are removed by catalytic reduction. (Water Treatment Guide, 2018)

## Appendix 6. Crates

The demonstration model will have to be representative of the built real model in South Africa. This will imply that in the demo model the same components will be used than will actually be used. In South Africa one of the layers of the field is made up of crates for storage of the water. These crates are designed in such a way that they are easy to assemble but can also be fixed at fixed points. By this way of design errors and assembly problems are avoided.

The dimensions of the crate are:

Length (L): 708 mm

Width (W): 354 mm

Height (H): 150 mm

The weight of this unit is 3 kg.

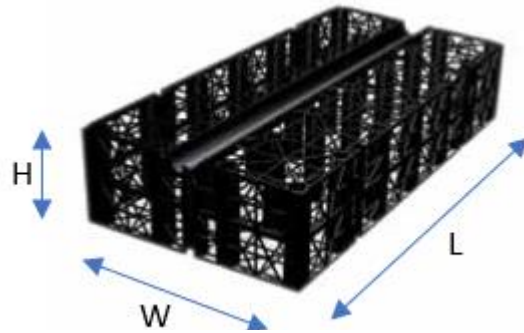

Figure 28 – Crate

The group discussed for a while and thought about the size of the pitch. The client wants a small pitch that can be played by a few people. So, the group decides that the length of the pitch will be something around 6 meters and the width something around 4 meters.

We have tried to get as close to the desired 6 and 4 meters as possible, but there are several possibilities to come close to the dimensions taken for the field. It has also been tried to stay below the desired size, which showed that at a size of:

Version 1: Length of 5664 mm with a width of 3894 mm and a height of 150 mm

or

Version 2: Length of 5310 mm with a width of 3540 mm and a height of 150 mm

Version 1 will need 80 crates and version 2 will need 88 crates in total.

When the crates with a height of 150 mm will create a too large water storage, it is still possible to choose from the crates with a height of 85 mm for a less water storage. With these crates nothing will change except the height, weight per crate and de volumetric void ratio, but otherwise the permissible forces and other dimensions remain the same.

To calculate the volume of a crate, use the standard formula: Length\*Width\*Height\*Volumetric void ratio.

Volumetric void ratio of crates with the height of 85 mm is 92% so that results in 19,6 litres per crate,  $7,08*3,54*0,85*0,92 = 19,599 \text{ dm}^3 = 19,6 \text{ litres}$ .

Volumetric void ratio of crates with the height of 150 mm is 95% so that results in 35,7 litres per crate,  $7,08*3,54*1,5*0,95 = 35,715 \text{ dm}^3 = 35,7 \text{ litres}$ .

Element	85mm	150mm
<b>Physical Properties</b>		
Weight per unit	2.25kg	3kg
Weight per square metre	9kg	12kg
Length	708mm	708mm
Width	354mm	354mm
Depth	85mm	150mm
<b>Short Term Compressive Strength</b>		
Vertical	715kN/m <sup>2</sup>	715kN/m <sup>2</sup>
Lateral	156kN/m <sup>2</sup>	156kN/m <sup>2</sup>
<b>Short Term Deflection</b>		
Vertical	1mm per 126kN/m <sup>2</sup>	1mm per 126kN/m <sup>2</sup>
Lateral	1mm per 15kN/m <sup>2</sup>	1mm per 15kN/m <sup>2</sup>
<b>Tensile Strength</b>		
Of a single joint	42.4kN/m <sup>2</sup>	42.4kN/m <sup>2</sup>
Of a single joint at (1% secant modulus)	18.8kN/m <sup>2</sup>	18.8kN/m <sup>2</sup>
Bending resistance of unit	0.71kN/m	0.71kN/m
Bending resistance of single joint	0.16kN/m	0.16kN/m
Volumetric void ratio	92%	95%
Average effective perforated surface area	52%	52%
<b>Other Properties</b>		
Intrinsic permeability (k)	1.0 x 10 <sup>-5</sup>	1.0 x 10 <sup>-5</sup>
Ancillary	Permavoid Permatie	Permavoid Permatie
	Permavoid Shear Connector	Permavoid Shear Connector
Material	Polypropylene (PP)	Polypropylene (PP)

Figure 29 – Specifications crates

## Appendix 7. Artificial pitch

The pitch consists a few layers, such like crates, artificial grass and a damping layer.

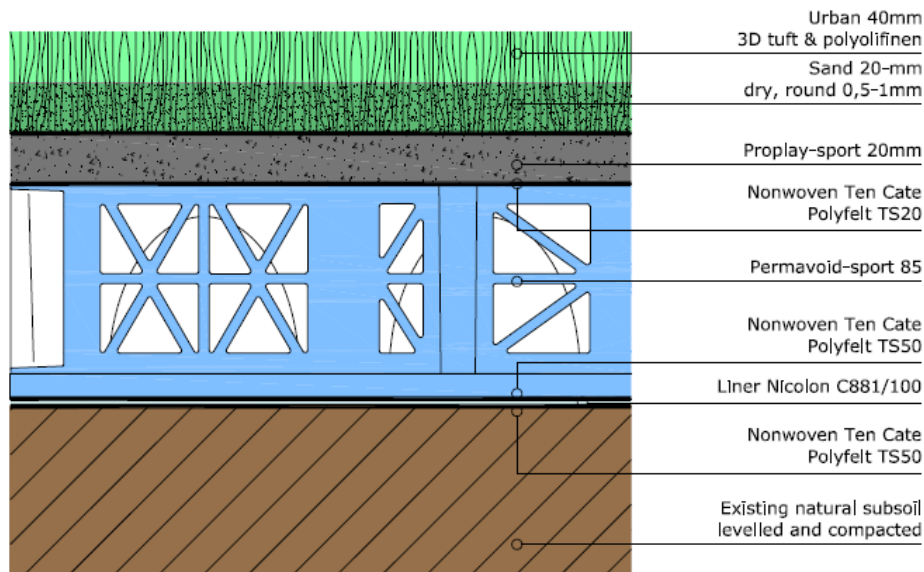

Figure 30 – Layers artificial pitch

### Artificial grass

Artificial grass is an artificial variety of grass and is upcoming and it is used for many purposes. Some purposes are sport fields, gardens, balconies and playground equipment for children. There are different types of artificial grass, but also the filling. There are different types of filling, which can consist of for example sand, rubber or cork.

The main reason of using artificial grass is maintenance. Artificial grass stands up to frequent and intense use, such like sports and it does not require irrigation or trimming.

For the dimensions of around 6 meters by 4 meters the project needs 24 square meters of artificial grass.

The grass will be delivered by Ten Cate B.V., because it is a partner of the project.

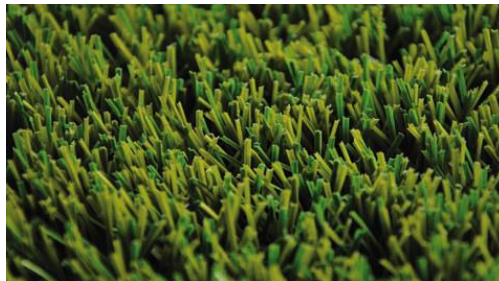

Figure 31 – Example artificial grass

## Damping

When someone plays on the crates and artificial grass it will be way too hard to play on, because there is no damping at all. So, between the artificial grass and the crates there have to be a layer for damping. This layer foam is engineered for maximum protection and comfort, so it will absorb and cushion the shock someone will make if there are walking, running or falling.

This foam is available in different formats, like the C-CUT, XC-CUT, C-CUT X or C-CUT X NW. The most difference of the formats is the thickness and the patron of the cuts.

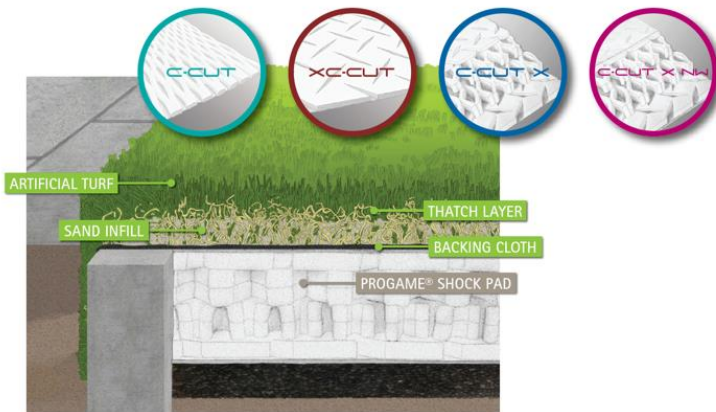

Figure 32 – Layers damping

## The TS–Polyfelt

Also, there is a layer for protecting the artificial grass from underside, this is the TS–Polyfelt stuff. TS–geotextiles ensure the uniform thickness of the base course by preventing the ingress of fill material into the fine–grained subgrade. Installation damage is prevented by the outstanding puncture resistance. The high tensile strength of TS in longitudinal, transverse and diagonal direction provides additional stability to the structure. TS–geotextiles maintain the permanent function of drainage systems and it offers excellent filtration properties, characterized by high water permeability and optimum soil–retention capability, even und high mechanic and hydraulic stress.



Figure 34 – Geotextile

## Waterproof

There will also be a layer to make the water storage waterproof, so there will be a layer for that.

(Greenfield USA, 2018) (TenCate Grass, 2018)

Properties <sup>[Standard]</sup>	Unit	TS 50
<b>Mechanical Properties</b>		
Tensile strength [EN ISO 10319]	MD CD	kN/m kN/m
		16 16
Elongation at max. load [EN ISO 10319]	MD CD	% %
		100 40
Energy value [EN ISO 10319]	(MD + CD)/2	J/mm <sup>2</sup>
		84
Static puncture resistance (CBR-Test) [EN ISO 12239]		N
		2350
Cone drop test (hole-Ø) [EN ISO 13433]		mm
		22
<b>Hydraulic Properties</b>		
Permeability vertical [EN ISO 11058] (Δh = 50 mm)		l/m <sup>2</sup> s (mm/s)
		90
Opening size O <sub>90</sub> [EN ISO 12956]		µm
		100
<b>Identification Properties</b>		
Thickness [EN ISO 9863-1]	2 kPa	mm
		1.9
Mass per unit area [EN ISO 9864]		g/m <sup>2</sup>
		200
<b>Forms of Supply</b>		

Figure 33 – Specifications TS Polyfelt



## Appendix 8. Siemens Logo! Program

The group used the software of Siemens Logo for the operating system of the system. On itself, the Software cannot perform anything, so it will still have to receive its instructions. These instructions are programmed using the "LOGO! Soft Comfort" program. In this program the command of the control of the entire system is programmed. This is done by means of a block diagram. These blocks consist of "Inputs" and "Outputs", but these inputs and outputs are combined into a working whole. The combining is done by the so-called AND and OR ports. In addition to these ports, NOT ports, Delay blocks and counters will also be used.

The AND and OR ports do what is in their name. An AND gate adds signals together and if all signals are "high" the AND gate transmits a "high" signal. An OR gate then indicates that one signal or the other signal is transmitting the OR gate a "high" signal.

Name	Input			Name	Output	Comment
Start	I1			MSG 1	Q1	Refill Tank 1
Tank 1 low	I2			MSG 2	Q2	Tank 1 Full 80%
Tank 1 High	I3			Tank 1 is Refilling	Q3	
Confirm MSG 1	I4			Tank 1 is Full	Q4	
Confirm MSG 2	I5			Pump 1 On	Q5	
Tank 3 Low	I6			Pump 1 Off	Q6	
Tank 3 High	I7			Pump 2	Q7	
FLOW in LG	I8			01-AV-01	Q8	
Pressure Sensor	I9			MSG 3	Q9	
Push Button (BackWash)	I10			01-	Q10	
Tank 2 Low	I11			01-AV-02	Q11	
Tank 2 High	I12			02-AV-01	Q12	
Confirm MSG 4	I13			02-AV-02	Q13	
Flow sensor	I14			02-AV-03	Q14	
				02-AV-04	Q15	
				01-AV-03	Q16	
Name Valve	Status Valve			MSG 4	Q17	Check Tank 1 and Tank 2
01-AV-01	NC					
01-AV-02	NC					
01-AV-03	NC					
02-AV-01	NO					
02-AV-02	NO					
02-AV-03	NO					
02-AV-04	NO					

Figure 35 – Inputs & outputs

In the Figure 35 the inputs, outputs and valves have been given a name. This way the operator knows which component he / she must connect to which input / out.

Now the operation of the created programs will be explained.

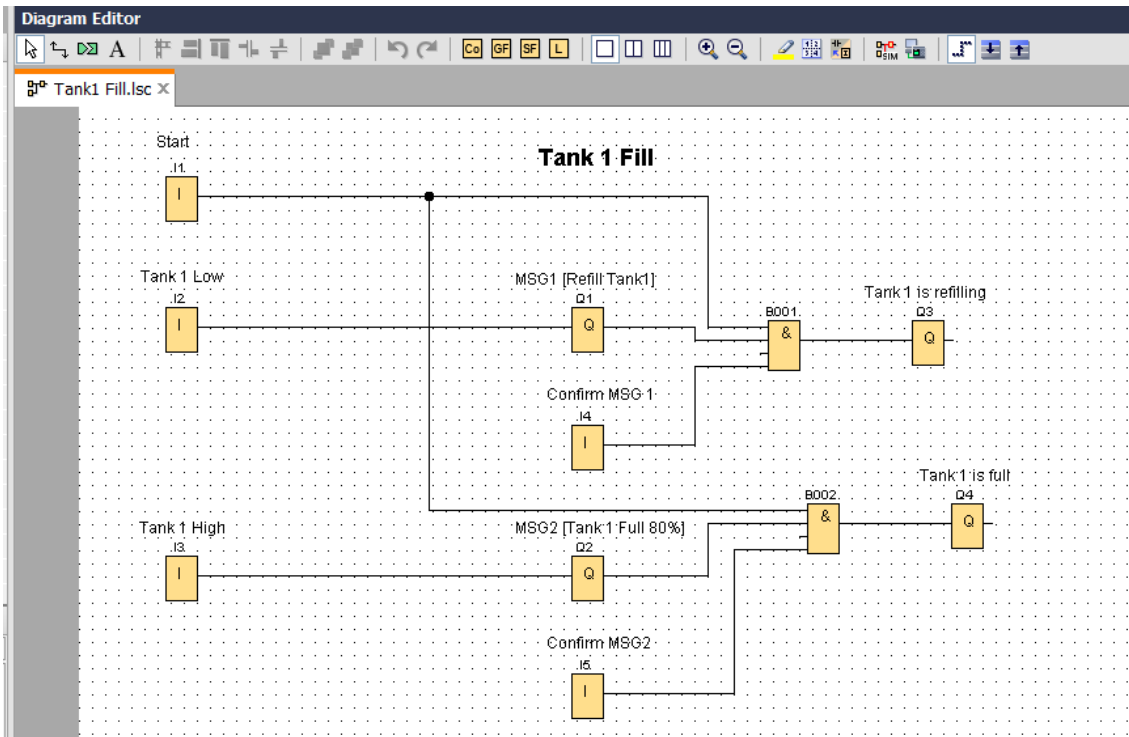

Figure 36 – Tank 1 Fill

For the next explanation use Figure 36 for the imaging to fill Tank1.

If the input "Tank1 Low" gets a high signal, Tank 1 is empty and will have to be filled. A message will appear on the screen with "Refill Tank1". This must be confirmed and then filled. This is filled manually and for this reason no pump is controlled. At the moment the tank is almost completely filled, a message will appear again on the screen. This message is controlled by the "Tank1 High" input that the sensor transmits.

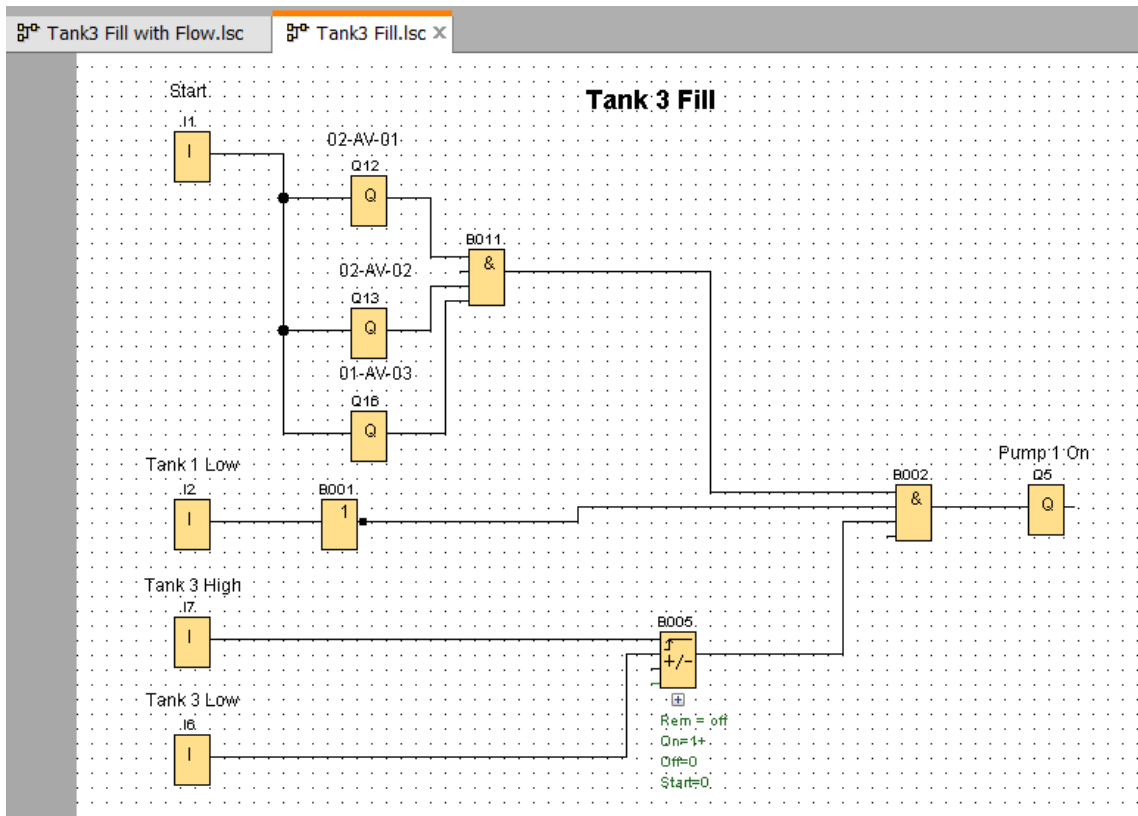

Figure 37 – Tank 3 Fill

For the next explanation use Figure 37 for the imaging to fill Tank3.

Before tank 3 can be filled and the pump starts to fill the tank, there are some conditions that have to be met. Some valves will have to be connected in the "Lineguard". Now some valves will have to be open and some have to be closed. Here the valves with the name "02-AV-03", "02-AV-04" and "01-AV-03" must be open and the valves "02-AV-01" and "02-AV-02" must be closed. If this is the case, then there will be looked at the signals coming from the different tanks. If the water is too low in tank 1, then the pump must not be on or off, therefore "NOT port" has been added. Now there will always be a high signal from "Tank1 Low" unless it does not have enough water and will switch. After this switching, there will no longer be a "high" signal to the "AND gate" and the pump will switch off or not on.

To start pump 1 another condition must be met. This is the signal that tank 3 is low. If this signal gives the pump goes on, but at the moment the pump comes on, water will enter the tank and there will be no signal from the sensor "Tank3 Low". This is correct, but now the pump will go out and that is not the intention. In order to ensure that the pump remains on until tank 3 is filled, a counter has been added here. This is set by the "Tank3 Low" and reset by the signal given by "Tank3 High" when tank 3 is full.

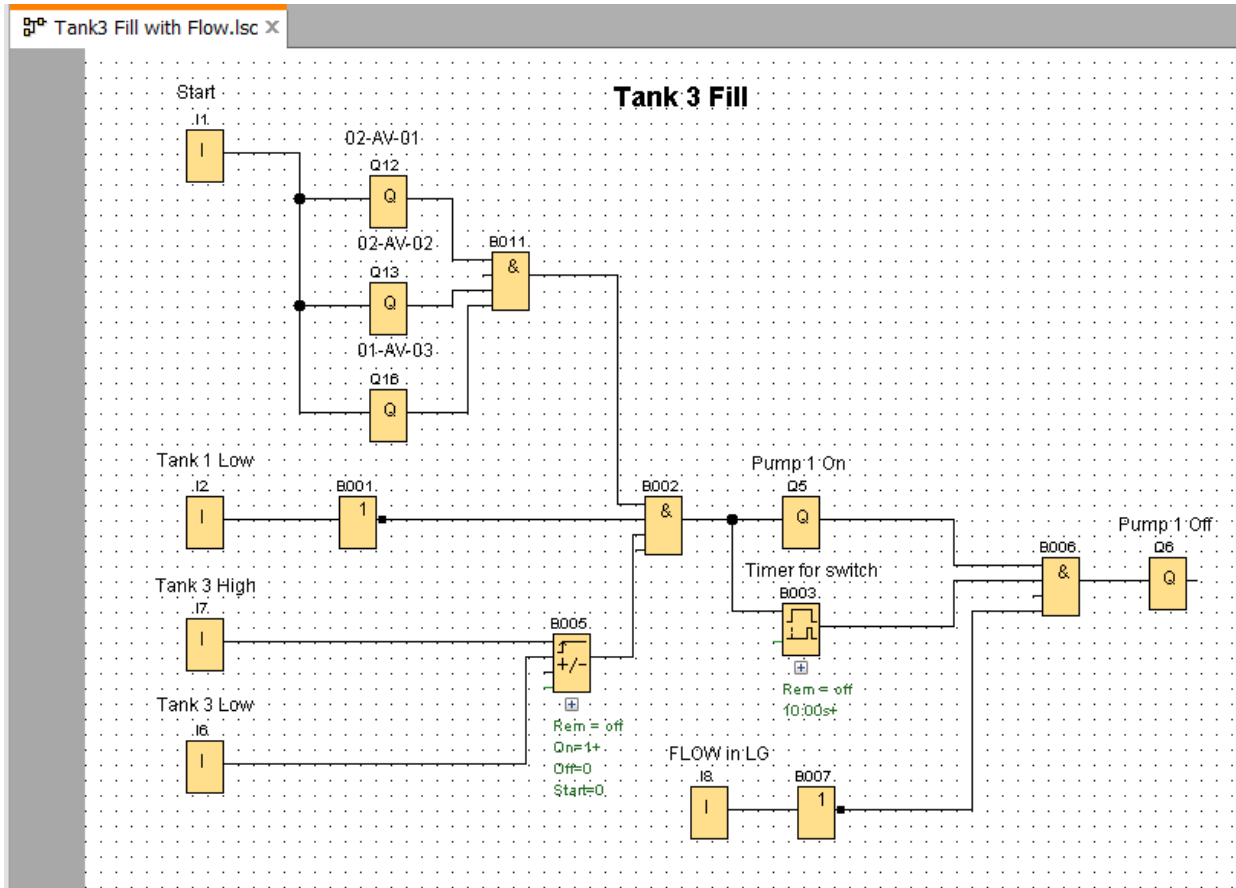
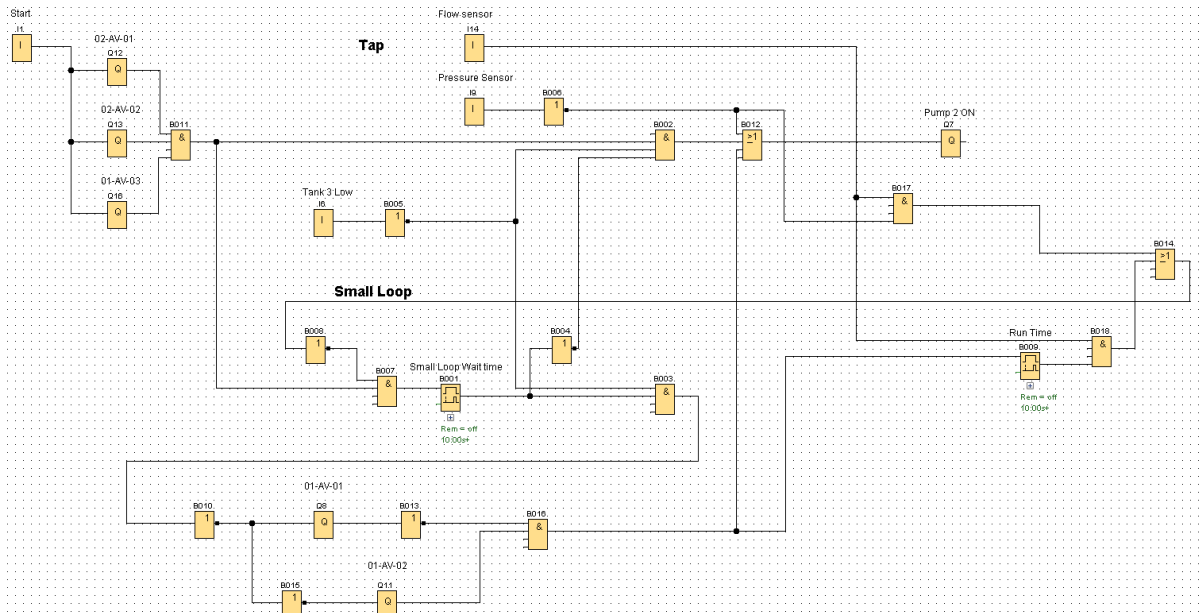

Figure 38 – Tank 3 Fill

For the next explanation use Figure 38 for the imaging to fill Tank3.

In this Figure 37 there is not much difference with the previous explanation about the filling of tank 3. With this filling of tank 3 only the expansion of the pump is added by means of a flow. The pump would go off when the previously set conditions are no longer fulfilled, but if no pump has been started or if there is a fault in the system, there would be no flow through the pipes and thus will not give a high signal. The flow is measured, but if it is not present after 10 seconds, there is a problem somewhere and the pump will be switched off, because then nothing can go wrong. This is an extra safety in the system.



**Figure 39 – Small loop**

For the next explanation use Figure 39 for the imaging and clarify the tapping of water and the small-loop.

The system will have to stand in the position for tapping, because at any given moment someone could come to have a drink of clean drinking water. In order to ensure that taps can be made at any time, the flaps will have to be in the position to tap. This means that the valves "02-AV-01", "02-AV-02" and "01-AV-02" must be closed. To tap water tank 3 will not be empty and the small loop will not be allowed to be switched.

The small loop must be switched when the filtered water in tank 3 has been stand still for too long. If the water is not in motion, bacteria can settle in the water and people can be infected again, but this is prevented by the small loop. After the time has elapsed and the small loop is activated, the valves "01-AV-01" and "01-AV-02" must switch. The "01-AV-02" valve will have to open and the "01-AV-01" valve will have to close. When these are closed and opened, the pump 2 starts to pump the water through the small-loop for a certain period of time and in this way the water will be clean.

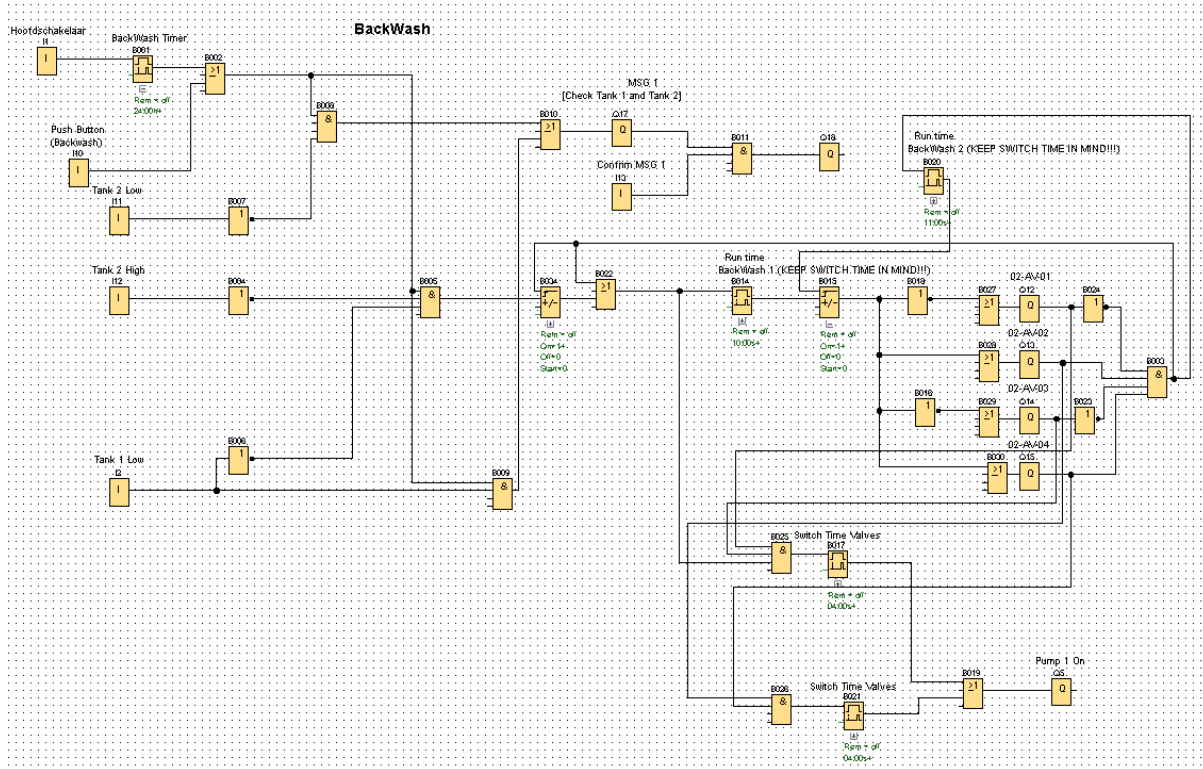

Figure 40 – Backwash

For the next explanation use Figure 40 for the imaging and clarify the cleaning part of the filters.

The backwash will be activated after the set time has elapsed, but also when the button is pressed. If the backwash wants to comply, the tank 1 must also not be too low. By switching the Lineguard's valves to a specific position, the lineguard can clean itself. Valves "02-AV-01" and "02-AV-03" will have to be open and the valves "02-AV-02", "02-AV-04" and "01-AV-03" must be closed /to become. Also, the level in tank 2 may not be too high. If the conditions of the tanks do not meet, a report will be made so that attention is paid to checking tanks 1 and 2.

If the tanks meet the conditions, the backwash can continue and the valves will already be connected to perform the first backwash. After it has satisfied the backwash for a certain period of time, one side of the line guard is clean. Now the other side of the lineguard will have to be cleaned by means of the backwash. First, the valves that are in the line guards will have to switch. This will mean that the valves "02-AV-01" and "02-AV-03" will have to be closed and the valves "02-AV-02", "02-AV-04" must be opened. The "01-AV-03" valve must remain closed. The backwash will start again and the other side of the line guard will be cleaned. The times that the lineguard will be counted, because after 2 times backwashing the system has to "reset" to start again.

## Appendix 9. Concepts

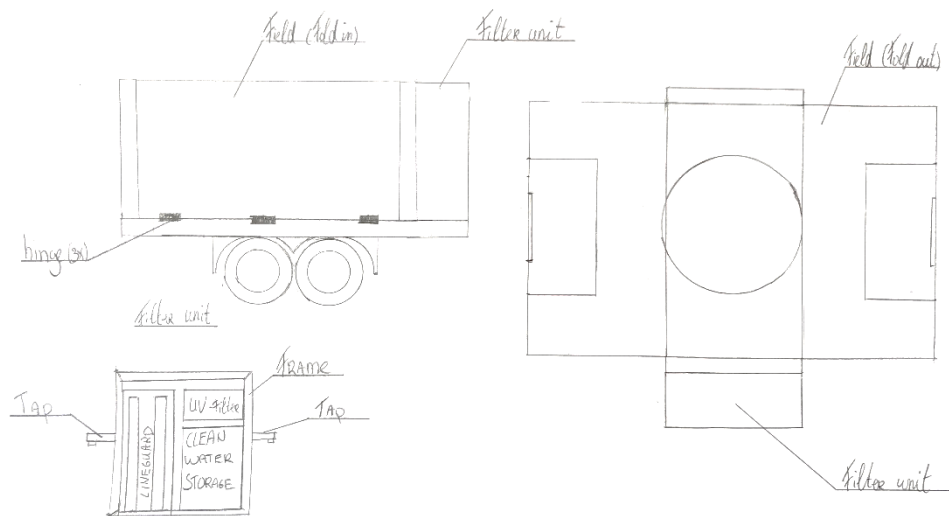
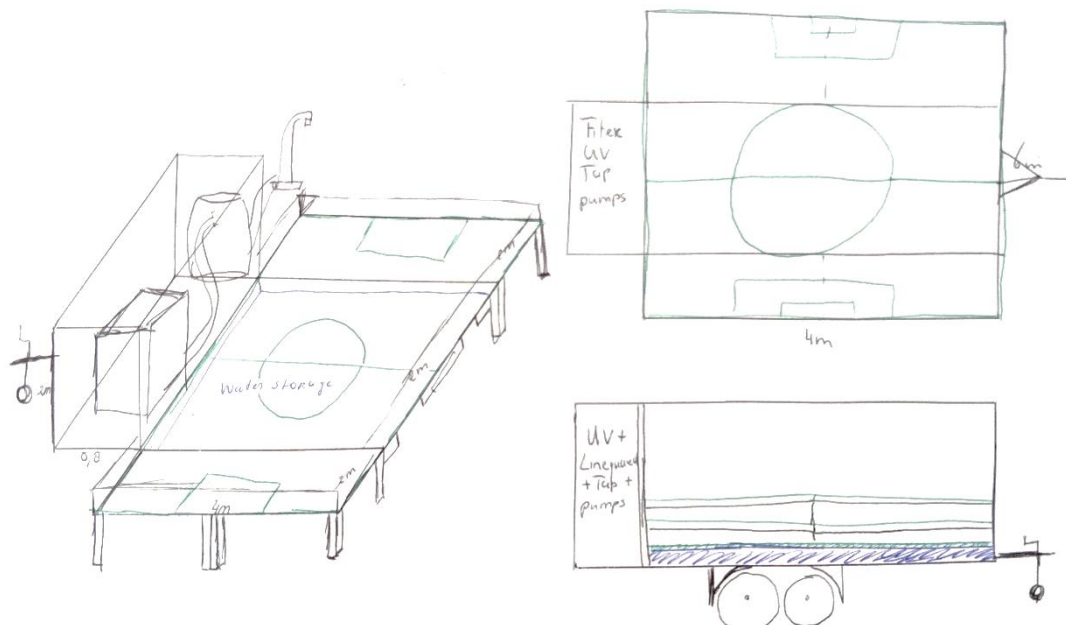

**Figure 41 – Concept 1**

This concept is based on a double axel trailer. It unfolds when it is on the demonstration site. The filter parts are mounted in one system skid on the back of the trailer. In this system skid the electrical and monitoring system is secured.

**Pros:** Good appearance, very quick setup, no extra trailer needed.

**Cons:** High purchase value, not very flexible, large dimensions.

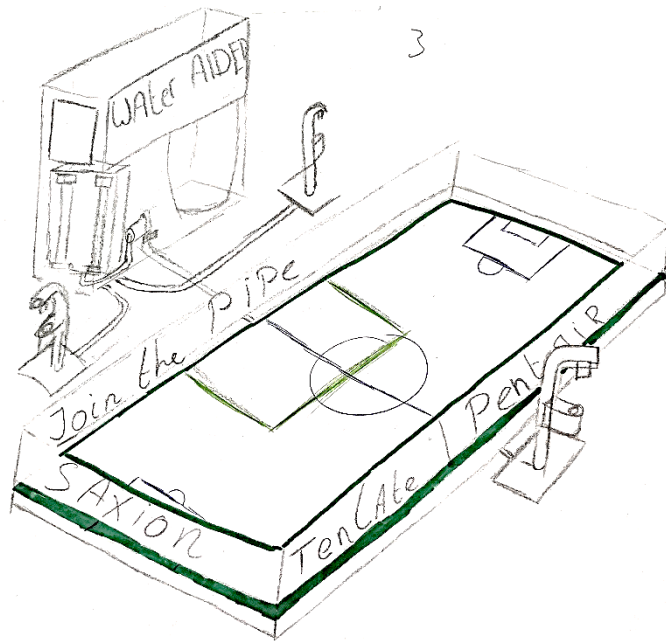

**Figure 42 – Concept 2**

The second concept is also a trailer-based concept. It looks similar at concept 1, but the layout is different and the water tap is set up next to the system skid.

**Pros:** Good appearance, quick setup, no extra trailer needed.

**Cons:** High purchase value, not very flexible, large dimensions.

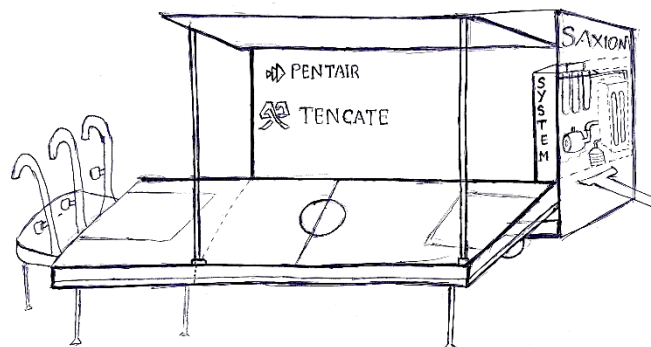

**Figure 43 – Concept 3**

This concept is not necessarily a trailer-based concept, it also could be a container-based concept. The system skid is also mounted at a fixed point. There are three water taps in this concept.

**Pros:** Good appearance, quick setup, no extra trailer needed.

**Cons:** Average purchase value, complicated construction.



**Figure 44 – Concept 4**

A special trailer with a roof and some walls, it looks great, but functionality is not so high.

**Pros:** Good appearance, very quick setup, no extra trailer or components needed.

**Cons:** Very high purchase value, complicated construction.



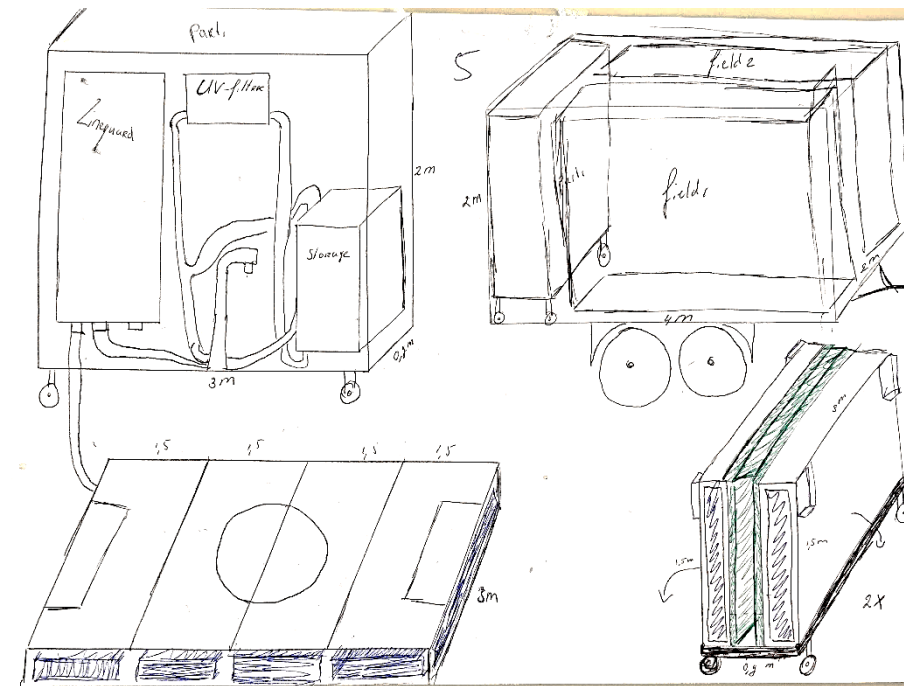

Figure 45 - Concept 5

Three loose components in a rent trailer or van. The dimensions of the components are relative small so this concept is very flexible. It definitely could fit through a door.

**Pros:** Incredibly flexible concept, low purchase value.

**Cons:** Must rent a trailer.

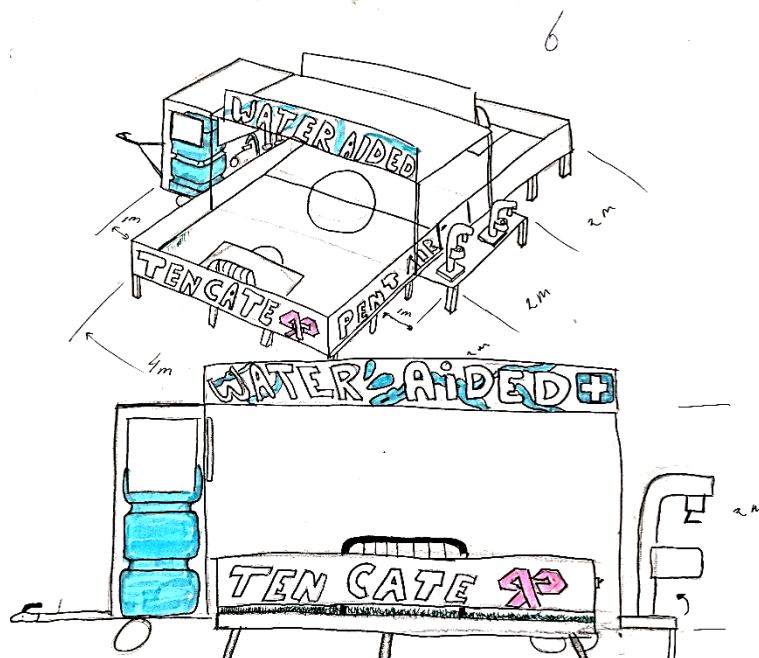

Figure 46 - Concept 6

Big trailer with fold-out walls. Everything is inside, therefore the set-up time is very short. Appearance can be dressed very nicely

**Pros:** Easy setup, very short setup time, appearance could be very nice.

**Cons:** Very expensive, not flexible at all, difficult construction.

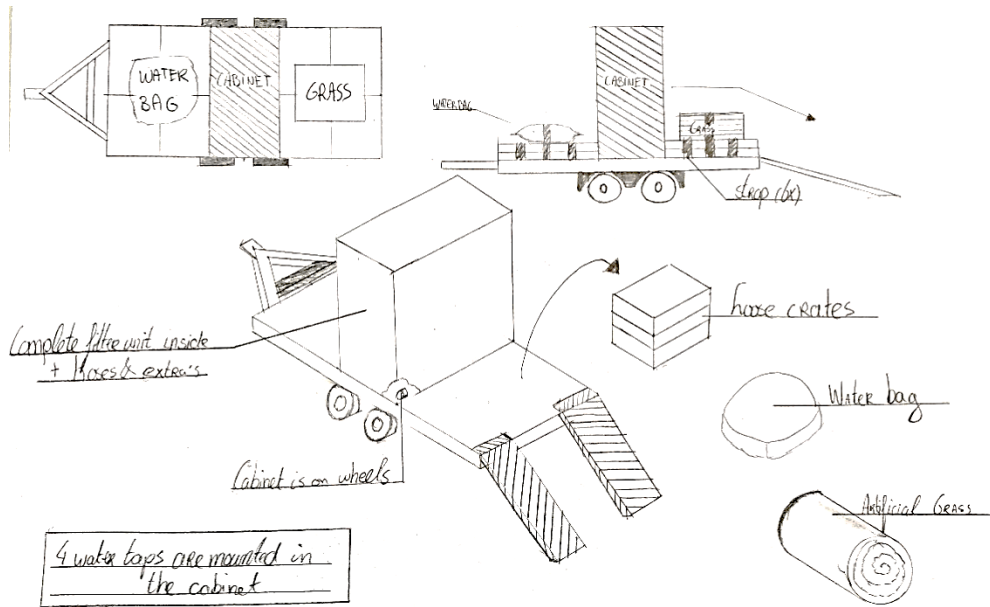

Figure 47 – Concept 7

Only loose parts with easy quick couplers. A bit more trouble with transporting the components.

**Pros:** Very low purchase value, very flexible.

**Cons:** To get a good appearance takes a lot of setup time.

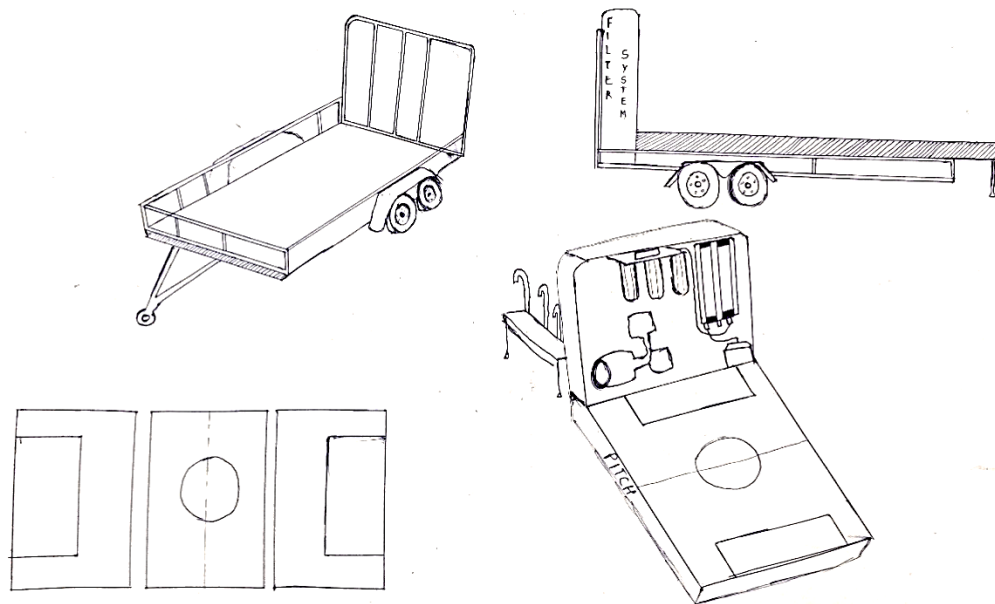

Figure 48 – Concept 8

Part of the system is folded upright, the field is on top of the rest of the trailer. This concept is not very flexible.

**Pros:** One trailer, very short setup time, average construction.

**Cons:** Not flexible, appearance is not very good

Multicriteria analysis concepts								
	1	2	3	4	5	6	7	8
Functionality	3	3	1	2	3	4	1	2
Cost	2	2	4	1	3	1	3	3
Simplicity	1	3	4	1	2	1	4	2
Setup time	4	3	1	4	2	4	1	3
Dimensions	1	3	4	3	3	1	3	2
Requirements	3	3	1	3	3	1	3	3
Design	3	3	1	4	3	3	2	2
Total	17	20	16	18	19	15	17	17

**Table 2 – Multicriteria analysis concepts**

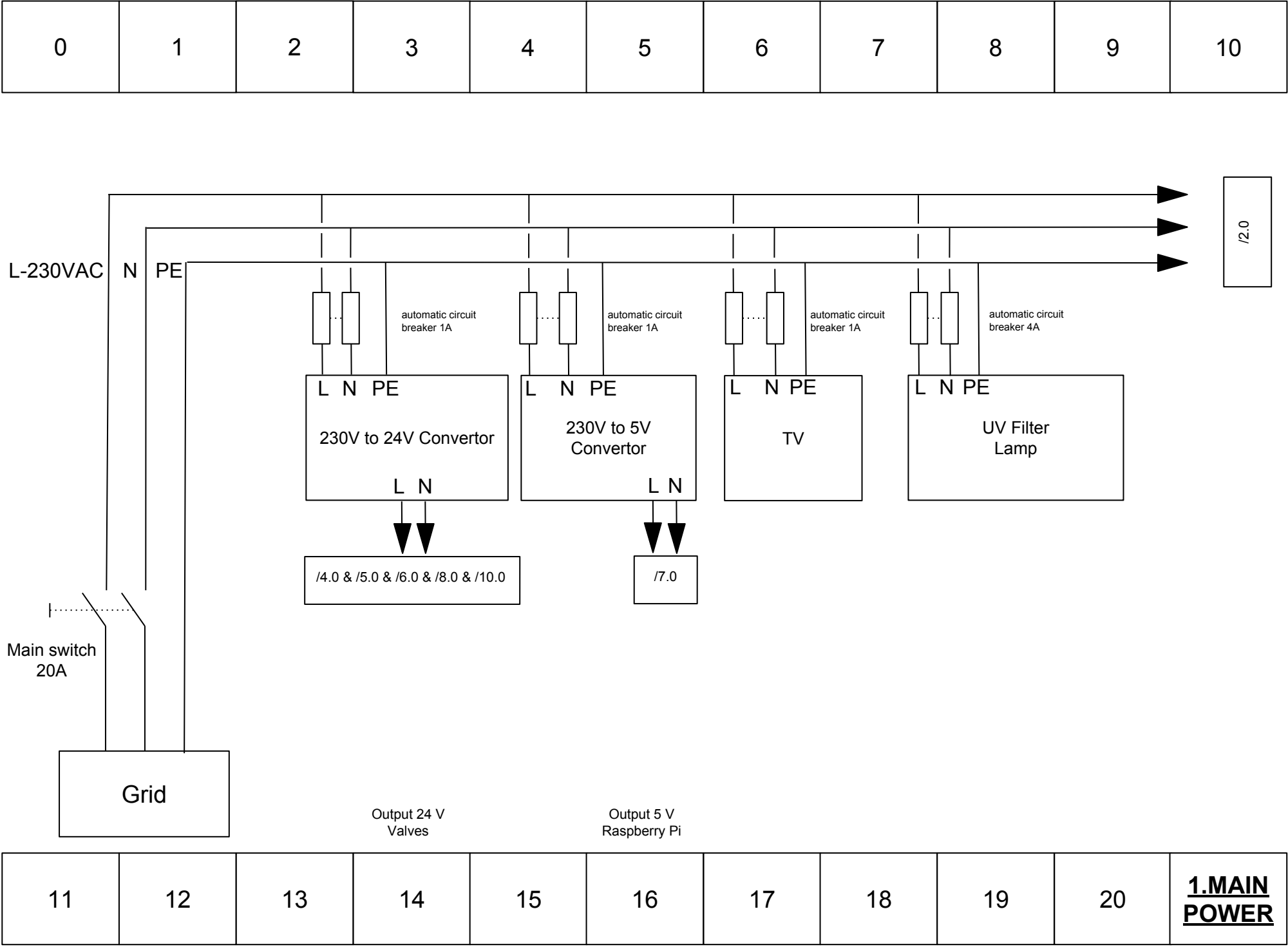

0	1	2	3	4	5	6	7	8	9	10
---	---	---	---	---	---	---	---	---	---	----

Pump 1

Pump 2

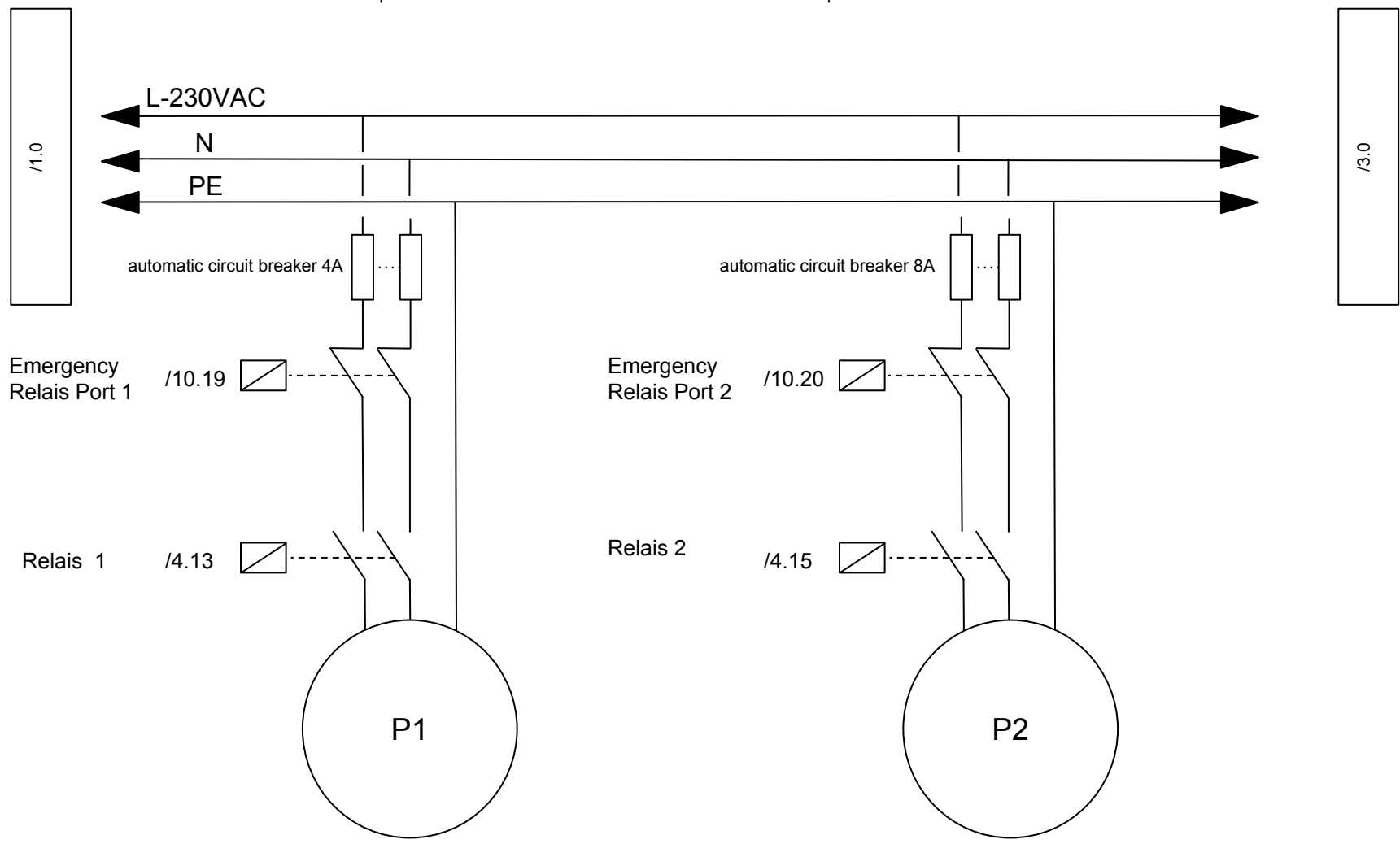

**2.PUMP**

0	1	2	3	4	5	6	7	8	9	10
---	---	---	---	---	---	---	---	---	---	----

Output 24 V  
Logo

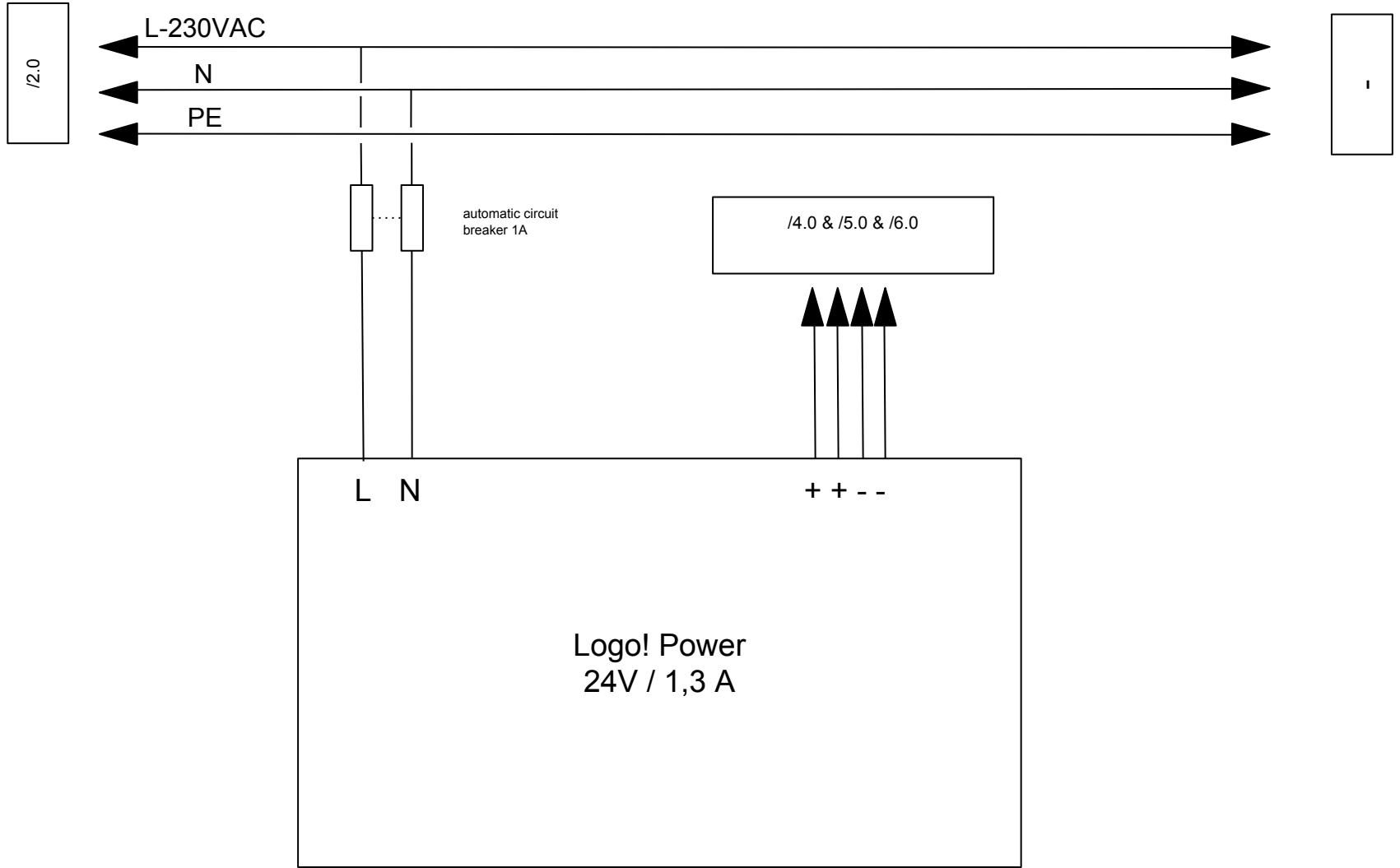

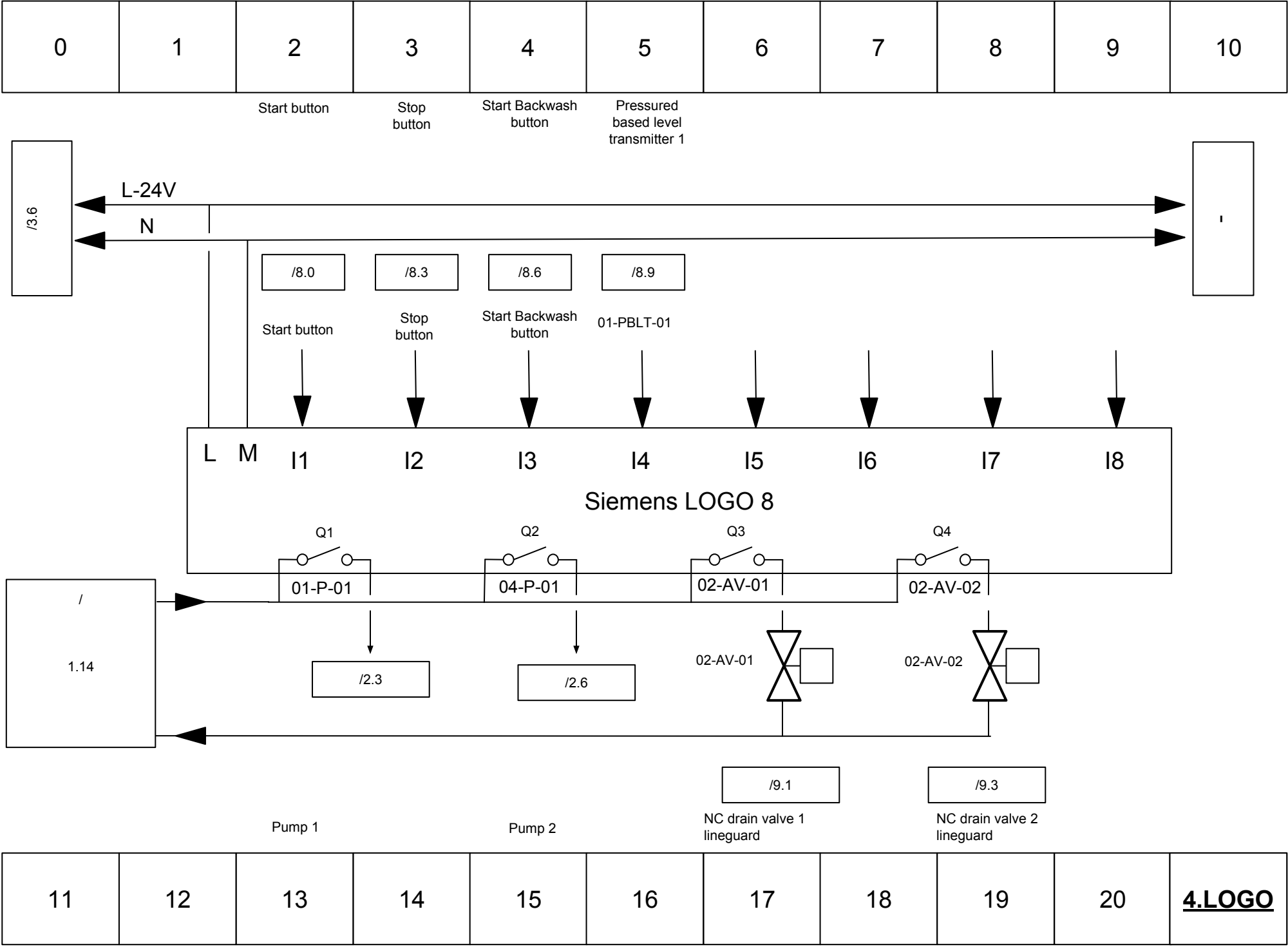

0	1	2	3	4	5	6	7	8	9	10
---	---	---	---	---	---	---	---	---	---	----

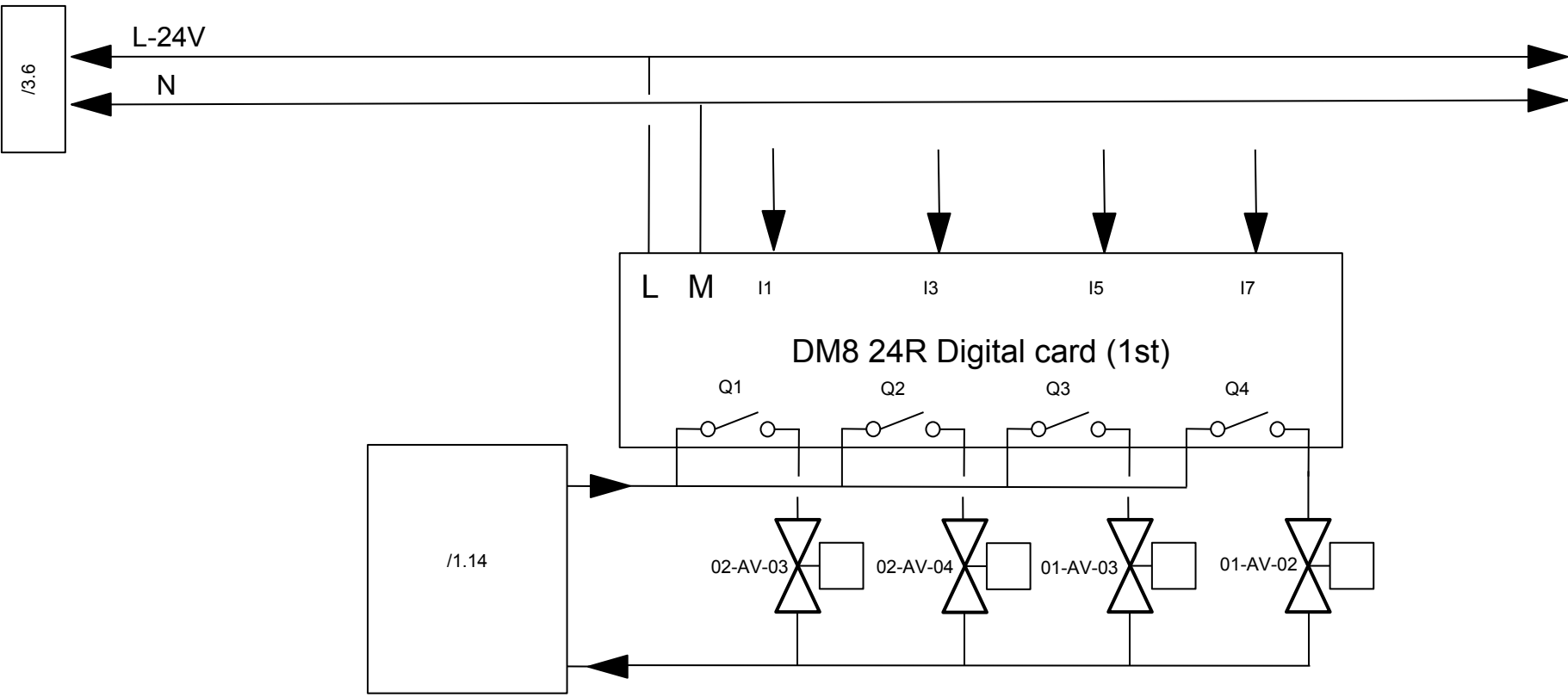

Automated drain valve 3 lineguard    Automated drain valve 4 lineguard    Filtered water shut off valve 1 lineguard    Filtered water shut off valve 1 lineguard

11	12	13	14	15	16	17	18	19	20	<b><u>5.DM8</u></b> <b><u>1ST</u></b>
----	----	----	----	----	----	----	----	----	----	--



0	1	2	3	4	5	6	7	8	9	10
---	---	---	---	---	---	---	---	---	---	----

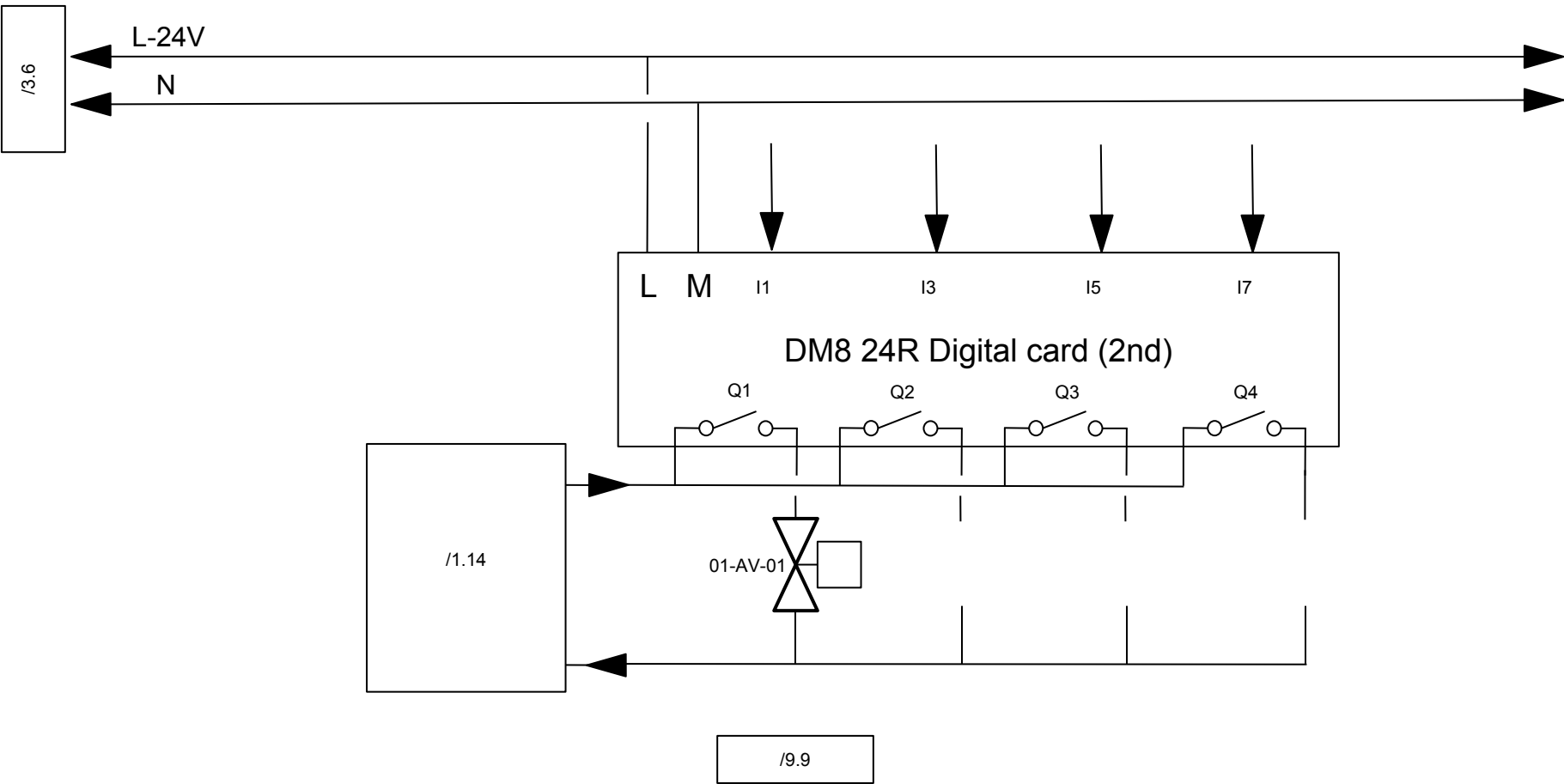

11	12	13	14	15	16	17	18	19	20	<b><u>6.DM8</u></b> <b><u>2ND</u></b>
----	----	----	----	----	----	----	----	----	----	--

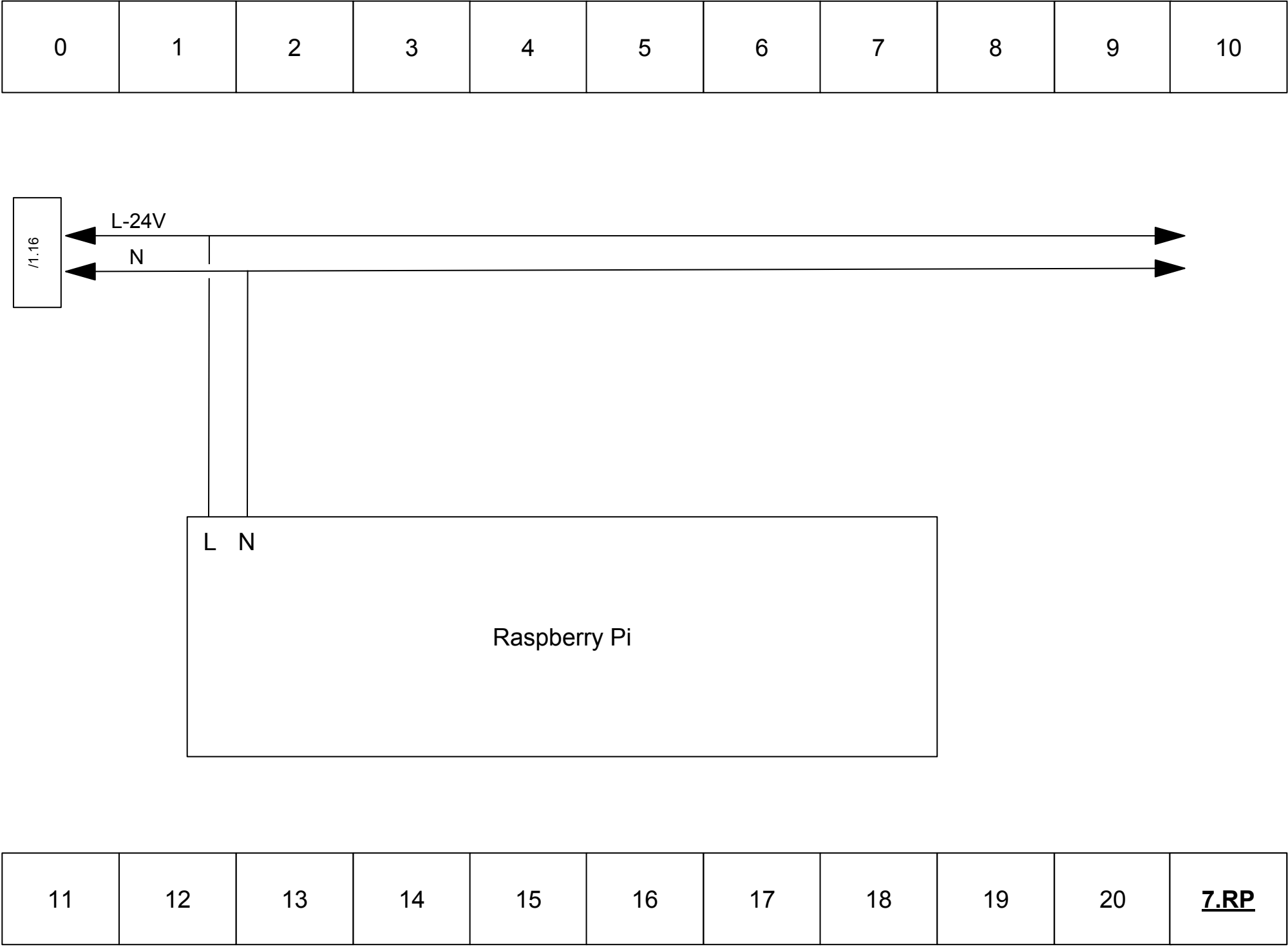

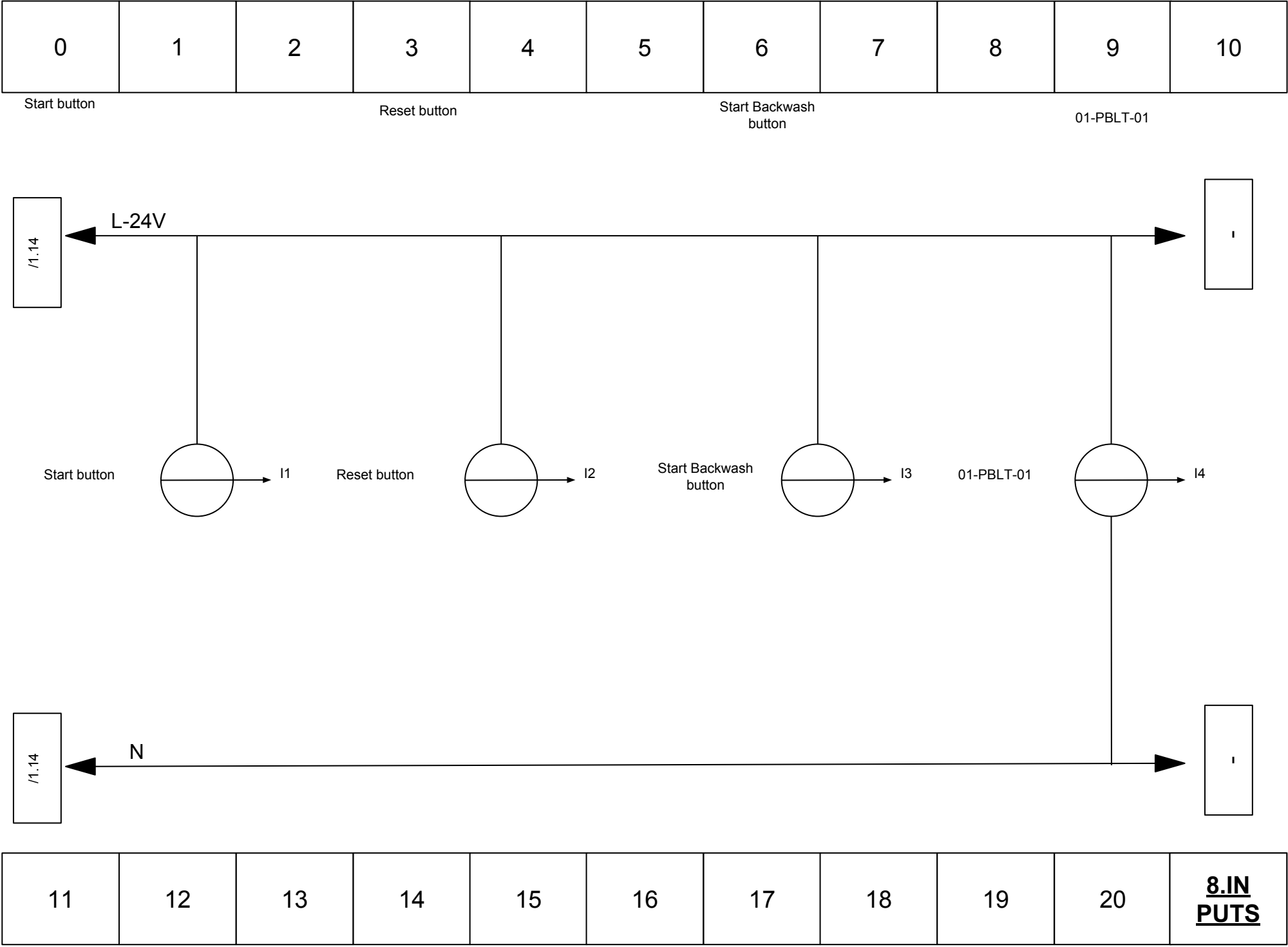

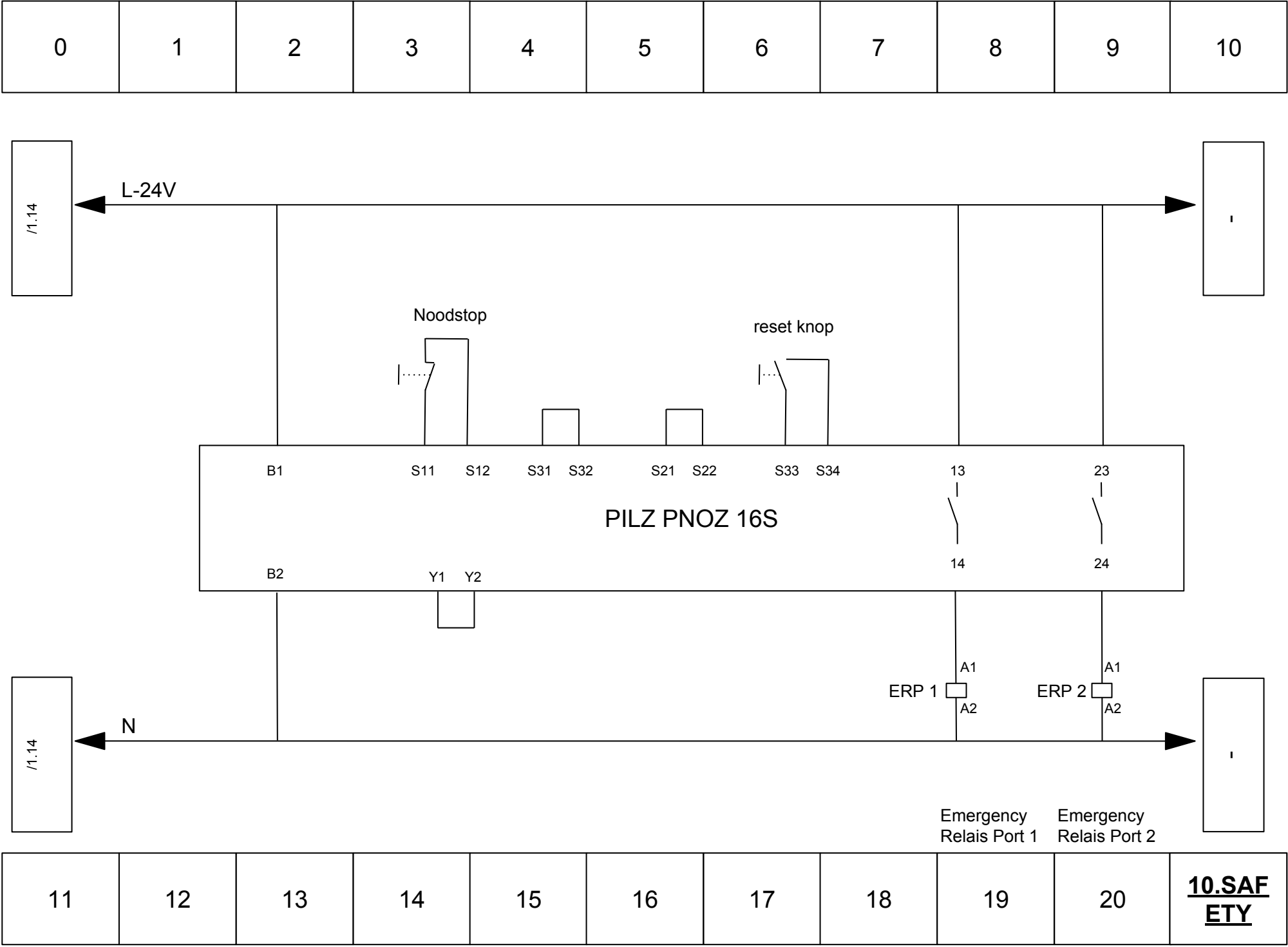

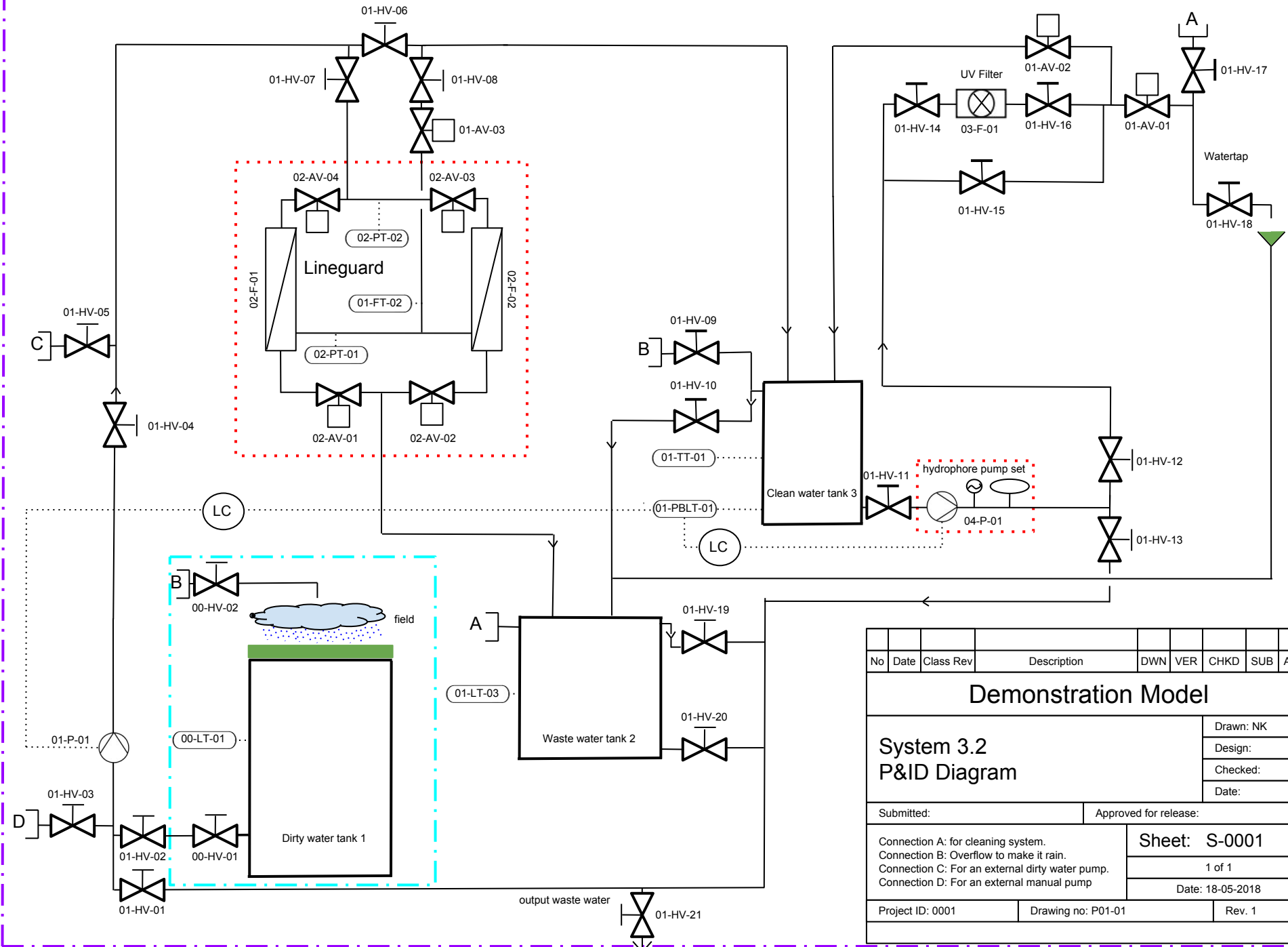

No	Date	Class	Rev	Description	DWN	VER	CHKD	SUB	APP
<b>Demonstration Model</b>									
<b>System 3.2 P&amp;ID Diagram</b>								Drawn: NK	
								Design:	
								Checked:	
								Date:	
Submitted:					Approved for release:				
Connection A: for cleaning system. Connection B: Overflow to make it rain. Connection C: For an external dirty water pump. Connection D: For an external manual pump								Sheet: S-0001	
								1 of 1	
Project ID: 0001								Drawing no: P01-01	
Date: 18-05-2018								Rev. 1	

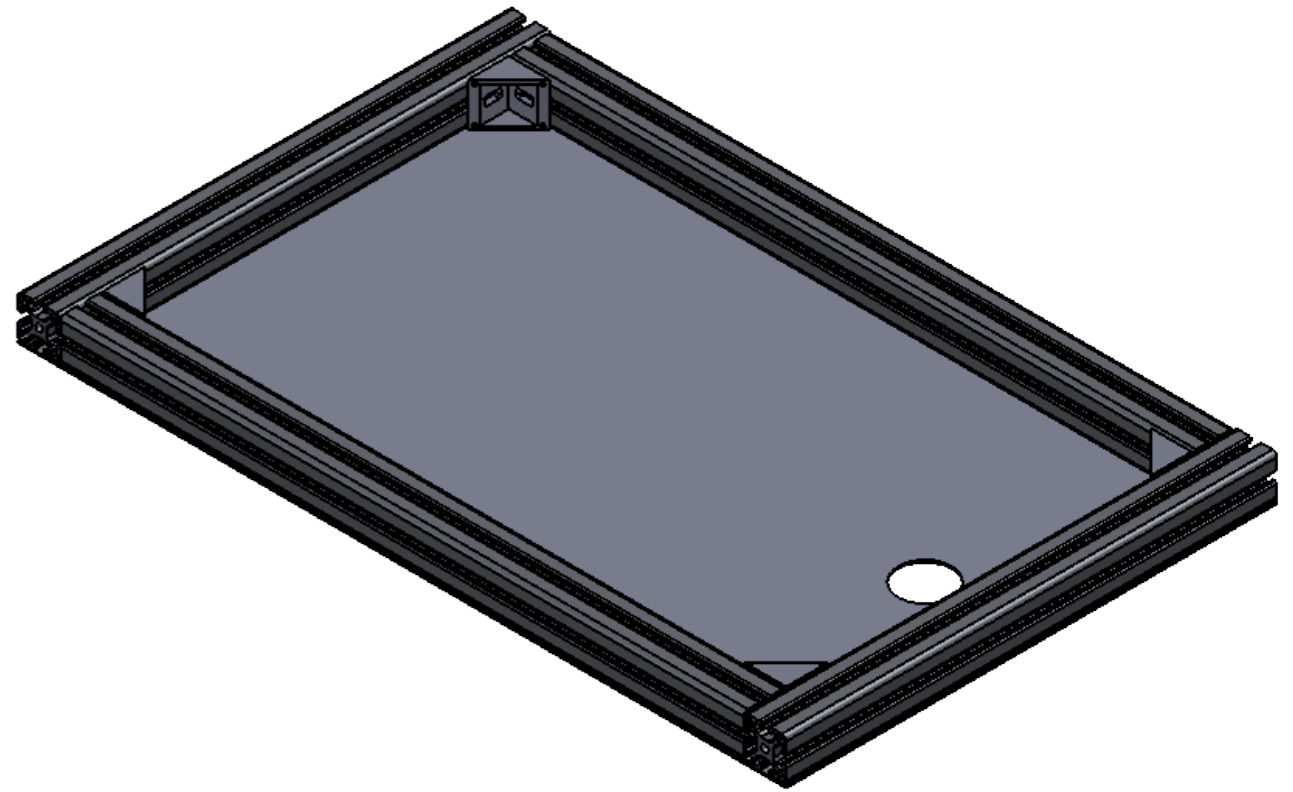
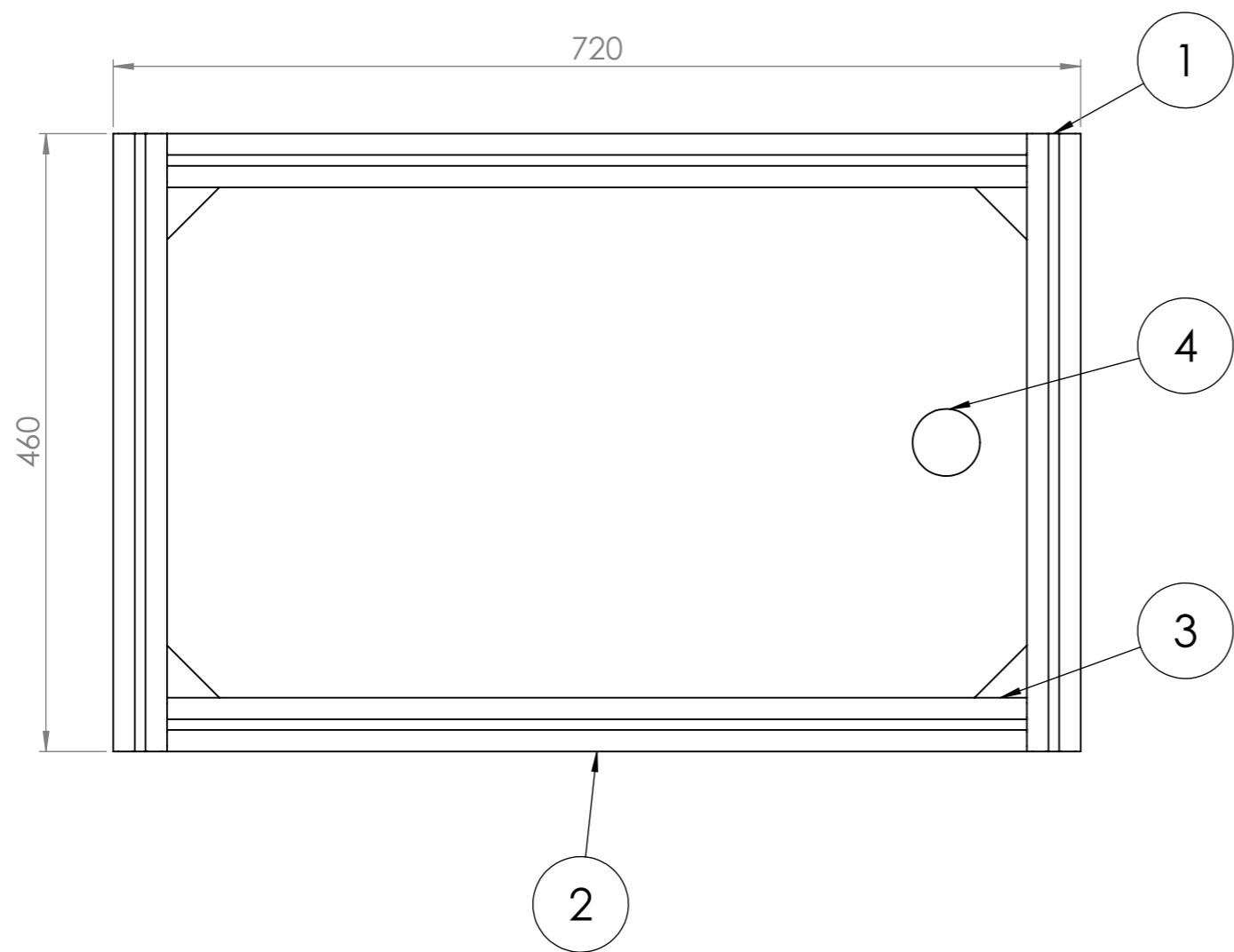

ITEM NO.	PART NUMBER	DESCRIPTION	QTY.
1	IBC 40 x 40 L=460mm		2
2	IBC 40 x 40 L=640mm		2
3	hoekverbinding		4
4	door cover		1

 Am. Projection	DIMENSIONS IN MILLIMETERS		DEBUR AND BREAK SHARP EDGES TOLERANCES ACCORDING TO: ISO 2768-mK		Finish:	
	Name		Signature		Date	
Drawn:					Material: Material <not specified>	
Checked:					Description:	
Class:		StudentNo.	Address: M.H. Tromplaan 28, 7513 AB Enschede, The Netherlands Postal address: P.O. Box 75000, 7500 KB Enschede, The Netherlands Phone: +31 53 4871111 Fax: +31 53 431 2233 Web: www.saxion.nl		Drawing number:	Revision:
					<b>door</b>	Format
					Weight: 5746.32	SCALE: 1:10
						SHEET: 1 OF 1

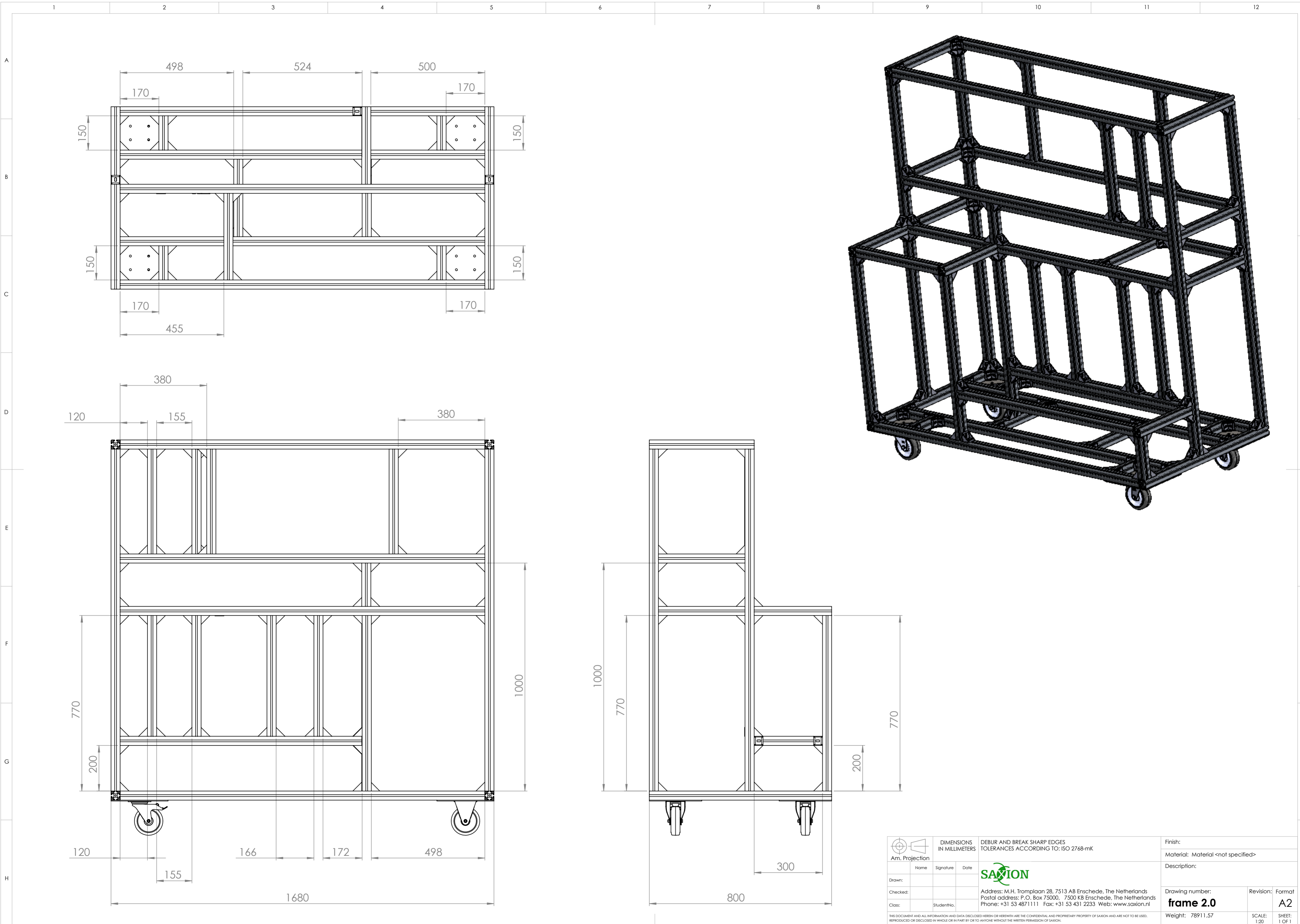

	DIMENSIONS IN MILLIMETERS		DEBUR AND BREAK SHARP EDGES TOLERANCES ACCORDING TO: ISO 2768-mK		Finish:	
					Material: Material <not specified>	
Name			Signature		Date	
Drawn:						
Checked:						
Class:			StudentNo.			
					Description:	
			Address: M.H. Tromplaan 28, 7513 AB Enschede, The Netherlands Postal address: P.O. Box 75000, 7500 KB Enschede, The Netherlands Phone: +31 53 4871111 Fax: +31 53 431 2233 Web: www.saxion.nl		Drawing number: <b>frame 2.0</b>	
					Revision: <b>1</b>	
					Weight: 78911.57	
					SCALE: 1:20	
					SHEET: 1 OF 1	

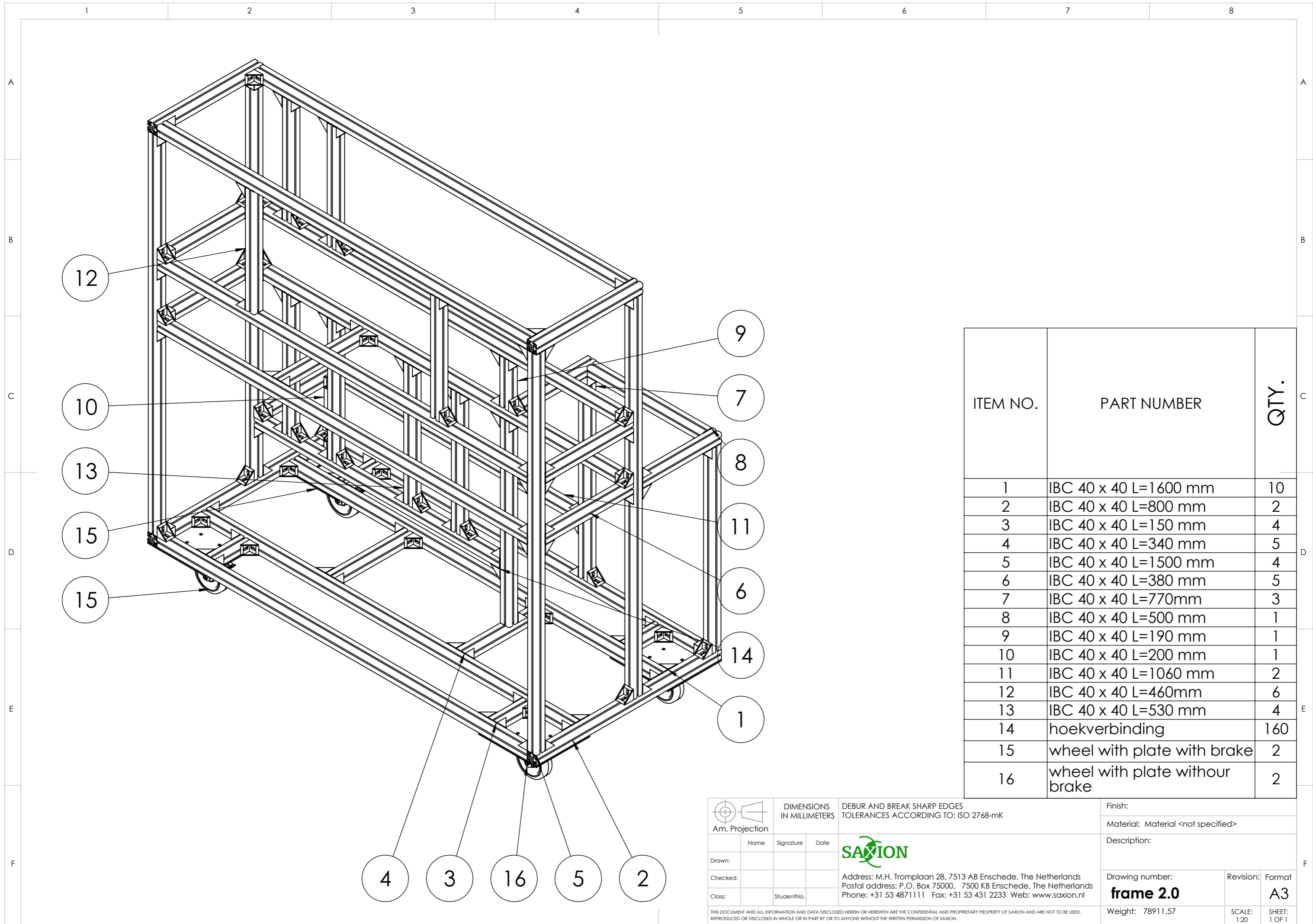

ITEM NO.	PART NUMBER	QTY.
1	IBC 40 x 40 L=1600 mm	10
2	IBC 40 x 40 L=800 mm	2
3	IBC 40 x 40 L=150 mm	4
4	IBC 40 x 40 L=340 mm	5
5	IBC 40 x 40 L=1500 mm	4
6	IBC 40 x 40 L=380 mm	5
7	IBC 40 x 40 L=770mm	3
8	IBC 40 x 40 L=500 mm	1
9	IBC 40 x 40 L=190 mm	1
10	IBC 40 x 40 L=200 mm	1
11	IBC 40 x 40 L=1060 mm	2
12	IBC 40 x 40 L=460mm	6
13	IBC 40 x 40 L=530 mm	4
14	hoekverbinding	160
15	wheel with plate with brake	2
16	wheel with plate without brake	2

 Am. Projection	DIMENSIONS IN MILLIMETERS DEBUR AND BREAK SHARP EDGES TOLERANCES ACCORDING TO: ISO 2768-mK			Finish: Material: Material <not specified>	
	Name	Signature	Date	Description:	
Drawn:				Drawing number: <b>frame 2.0</b> Revision:      Format: <b>A3</b>	
Checked:				Weight: 78911.57      SCALE: 1:20      SHEET: 1 OF 1	
Class:	StudentNo.			Address: M.H. Tromplaan 28, 7513 AB Enschede, The Netherlands Postal address: P.O. Box 75000, 7500 KB Enschede, The Netherlands Phone: +31 53 4871111 Fax: +31 53 431 2233 Web: www.saxion.nl	



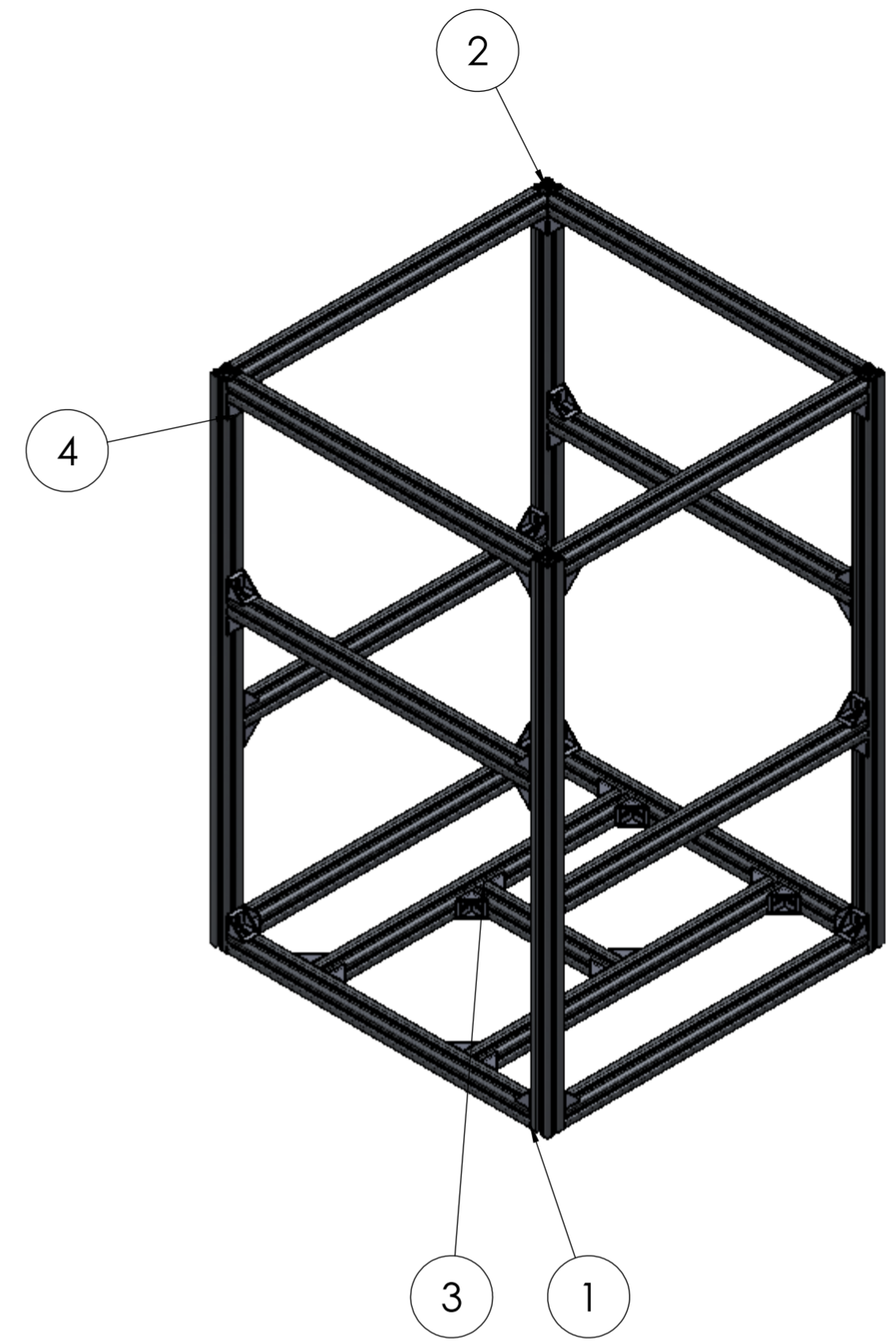
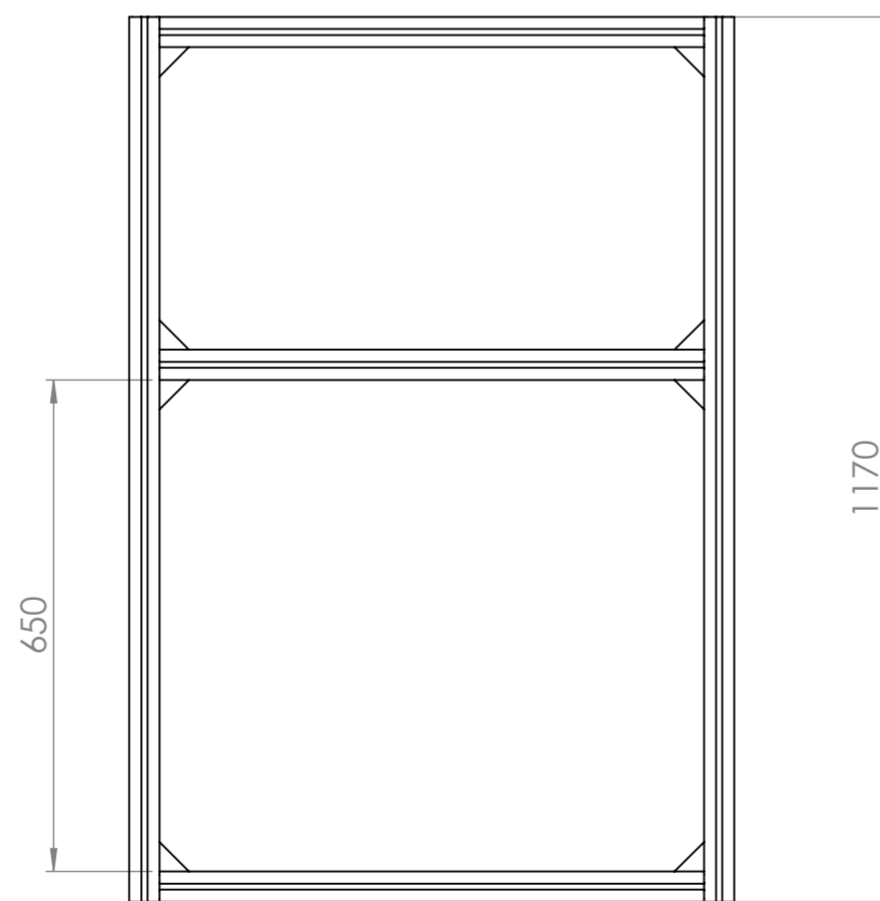
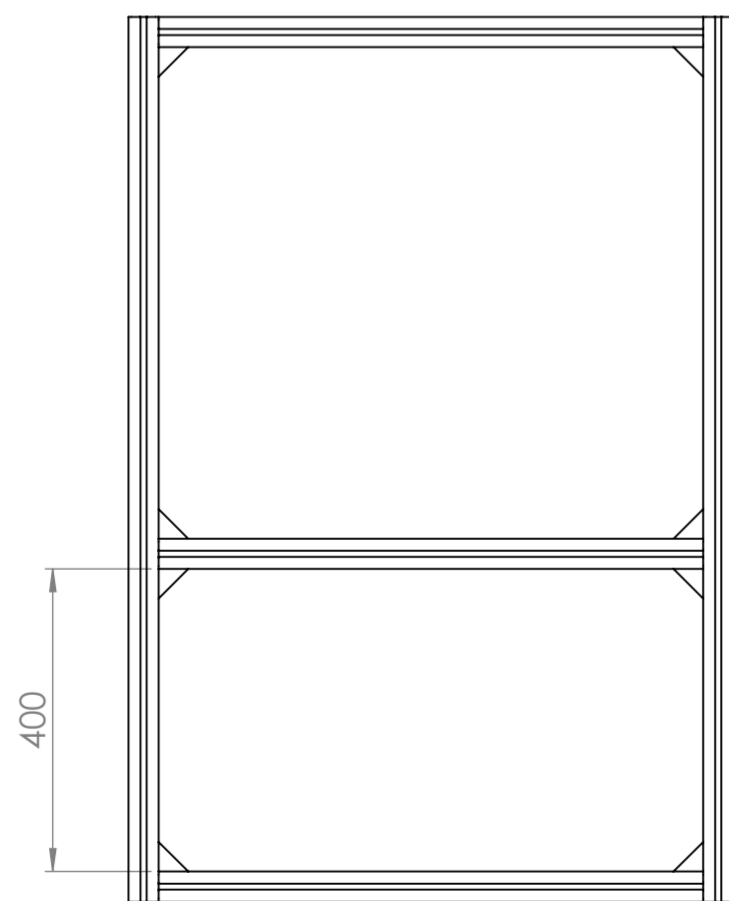
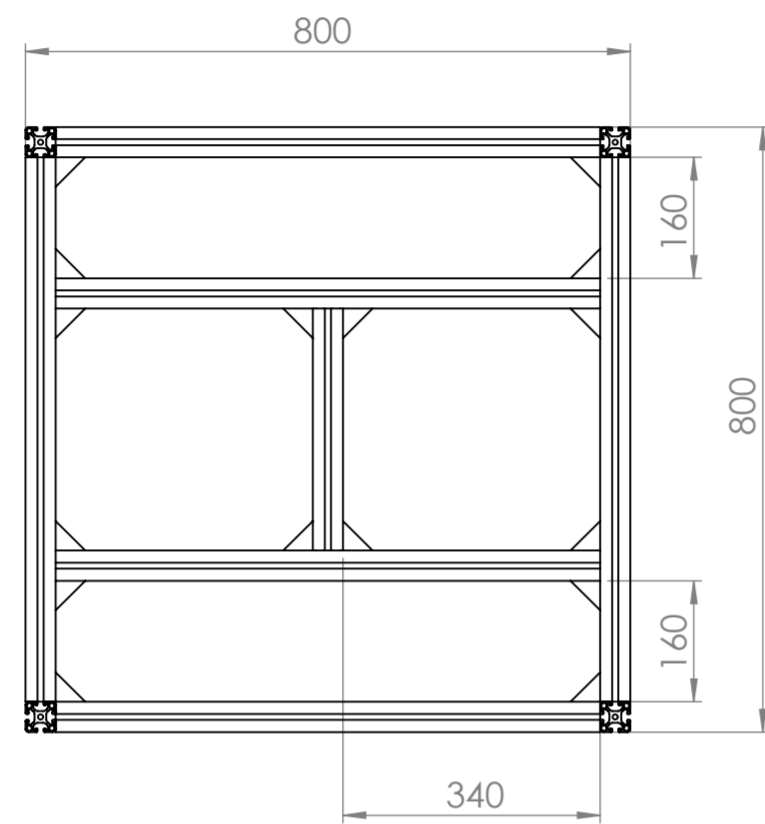

ITEM NO.	PART NUMBER	DESCRIPTION	QTY.
1	IBC 40 x 40 L=720 mm		14
2	IBC 40 x 40 L=1170 mm		4
3	IBC 40 x 40 L=320 mm		1
4	hoekverbinding		46

		DIMENSIONS IN MILLIMETERS DEBUR AND BREAK SHARP EDGES TOLERANCES ACCORDING TO: ISO 2768-mK		Finish: Material: Material <not specified>		
Name	Signature	Date				
Drawn:						
Checked:						
Class:	StudentNo.					
Address: M.H. Tromplaan 28, 7513 AB Enschede, The Netherlands Postal address: P.O. Box 75000, 7500 KB Enschede, The Netherlands Phone: +31 53 4871111 Fax: +31 53 431 2233 Web: www.saxion.nl			Drawing number: <b>Frame</b>		Revision:	Format: <b>A2</b>
THIS DOCUMENT AND ALL INFORMATION AND DATA DISCLOSED HEREIN OR HEREWITH ARE THE CONFIDENTIAL AND PROPRIETARY PROPERTY OF SAXION AND ARE NOT TO BE USED, REPRODUCED OR DISCLOSED IN WHOLE OR IN PART BY OR TO ANYONE WITHOUT THE WRITTEN PERMISSION OF SAXION.			Weight: 27505,14	SCALE: 1:10	SHEET: 1 OF 1	

# SFC-1-TAP in Words

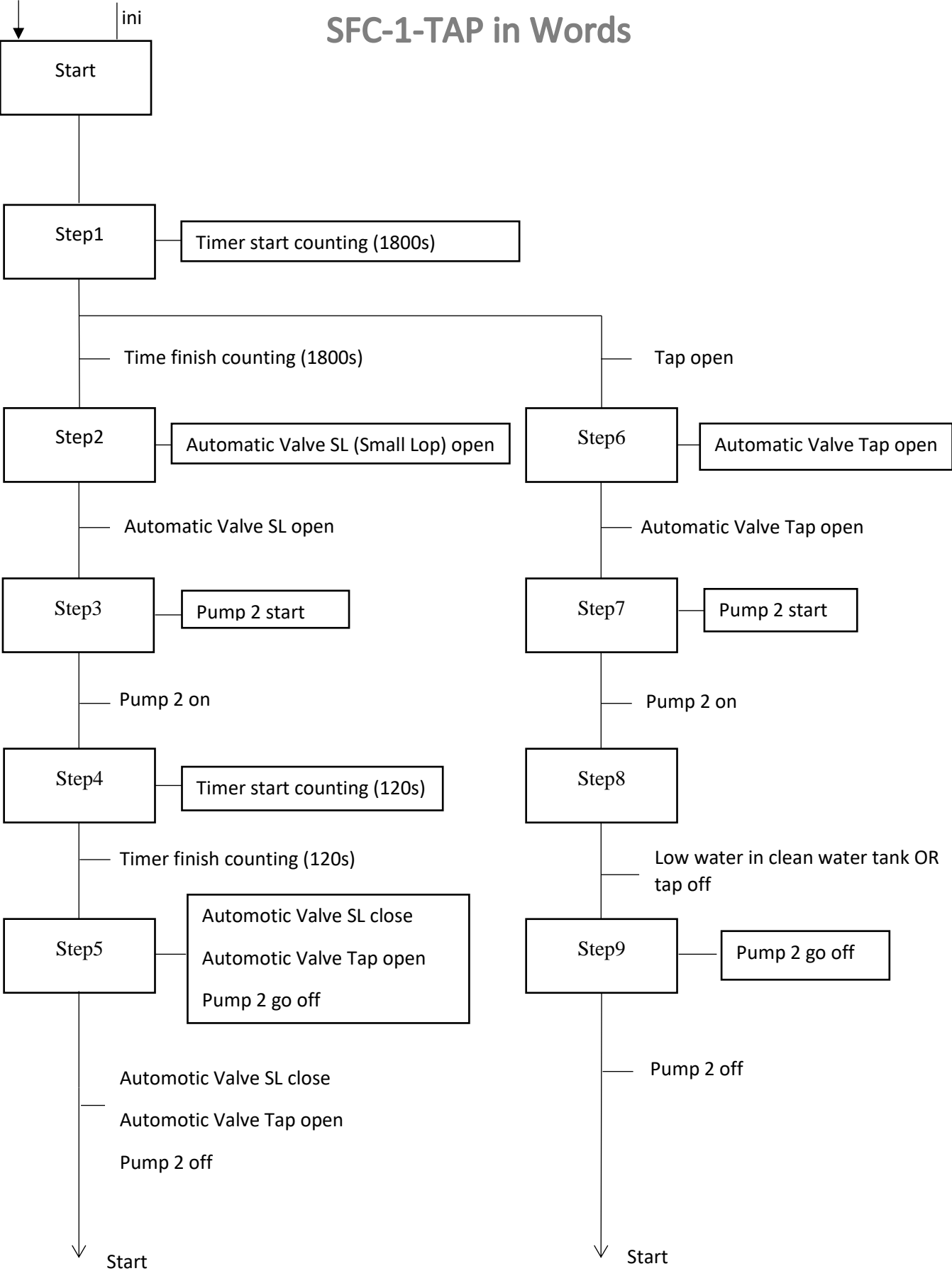

# SFC-1-TAP

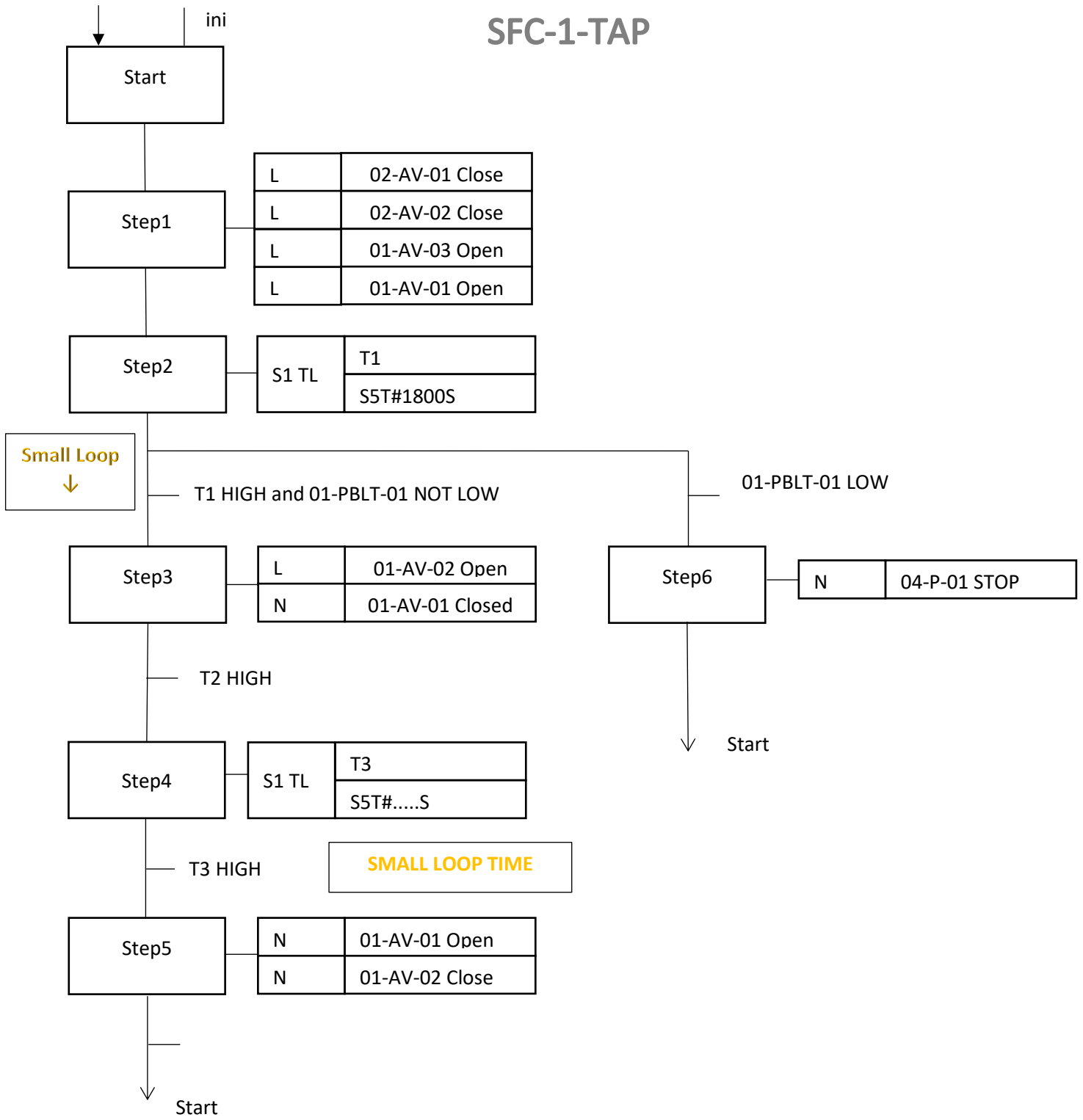

# SFC-2-TANK3FILL in Words

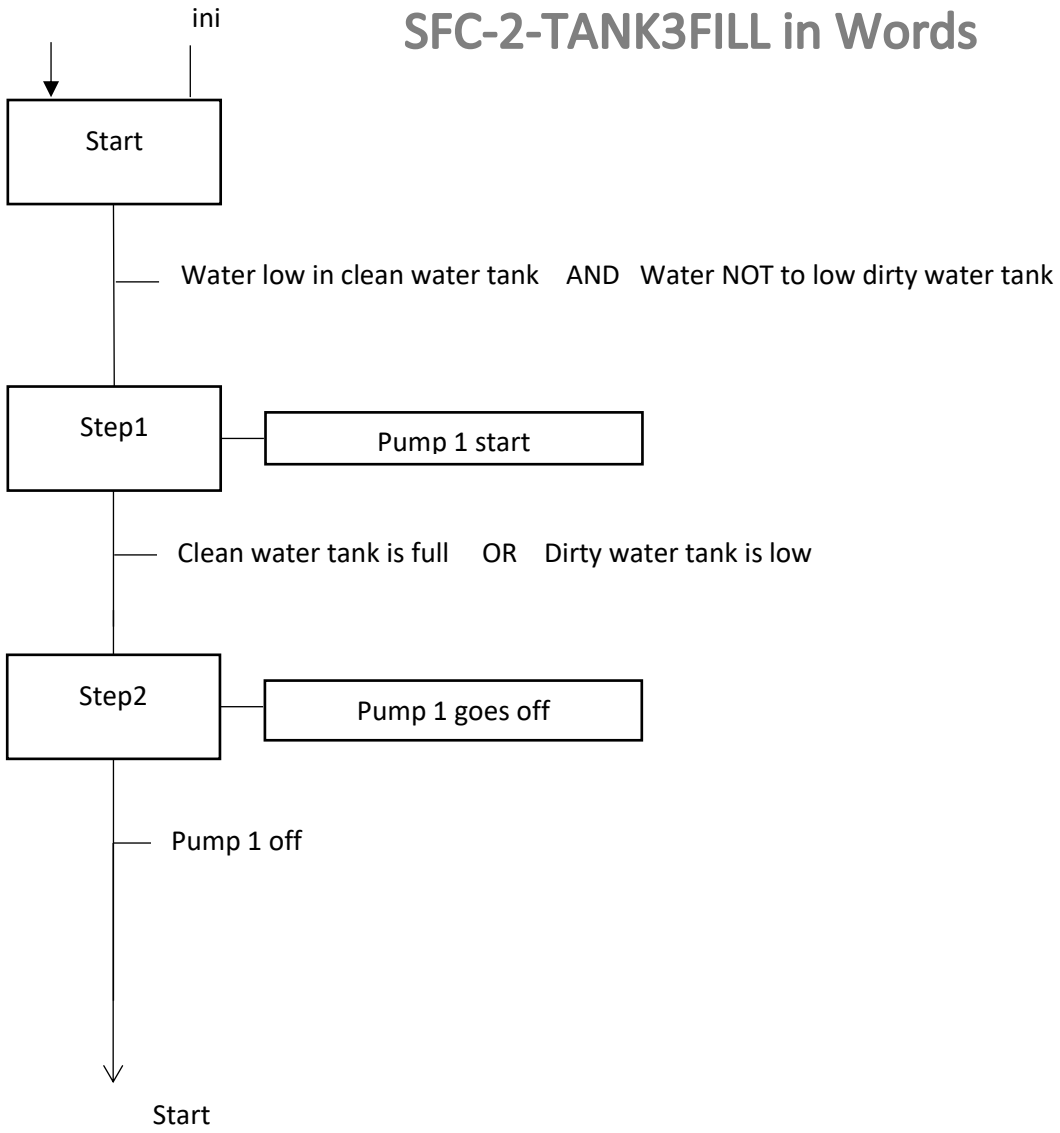

# SFC-2-TANK3FILL

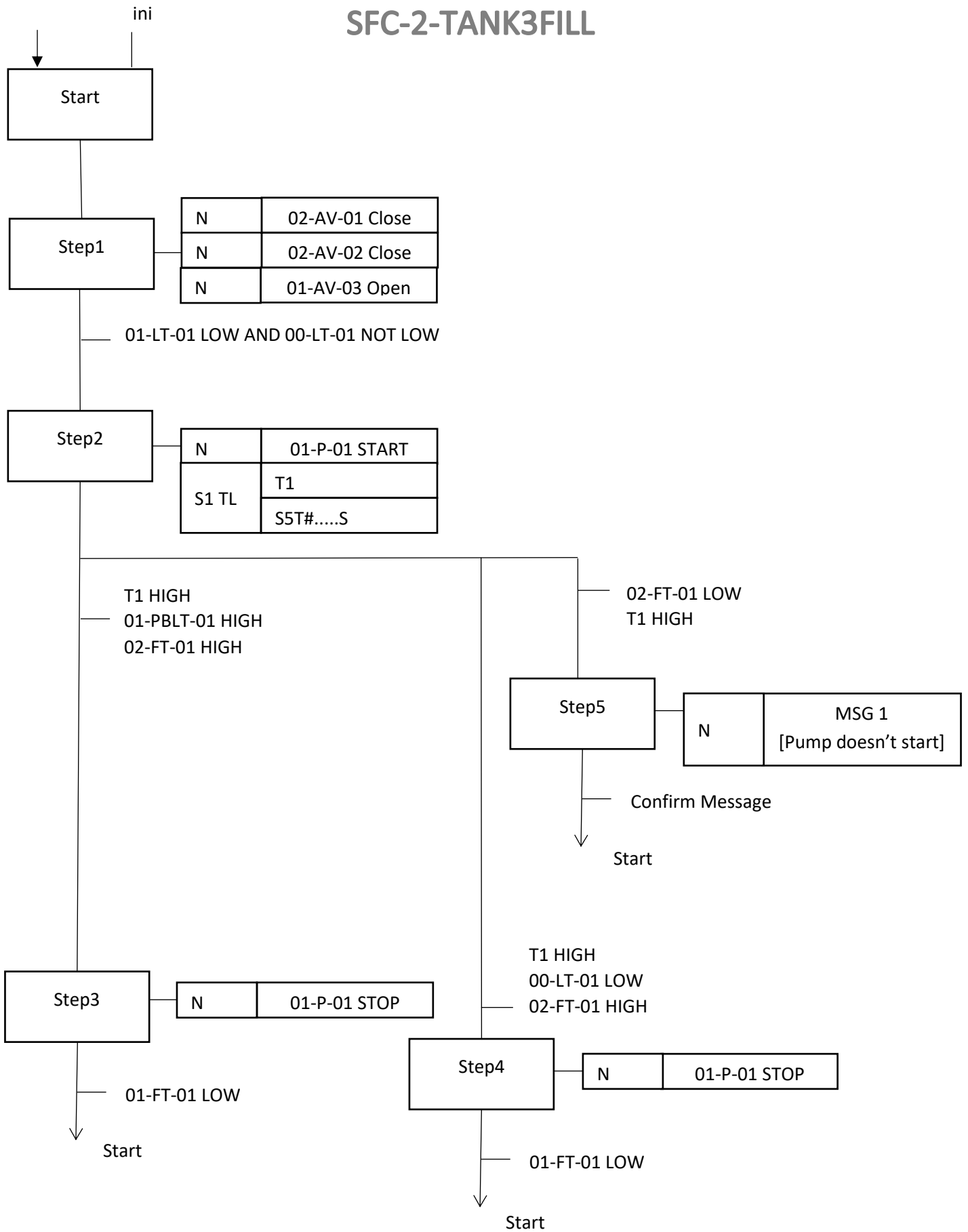

# SFC-3-TANK1FILL in Words

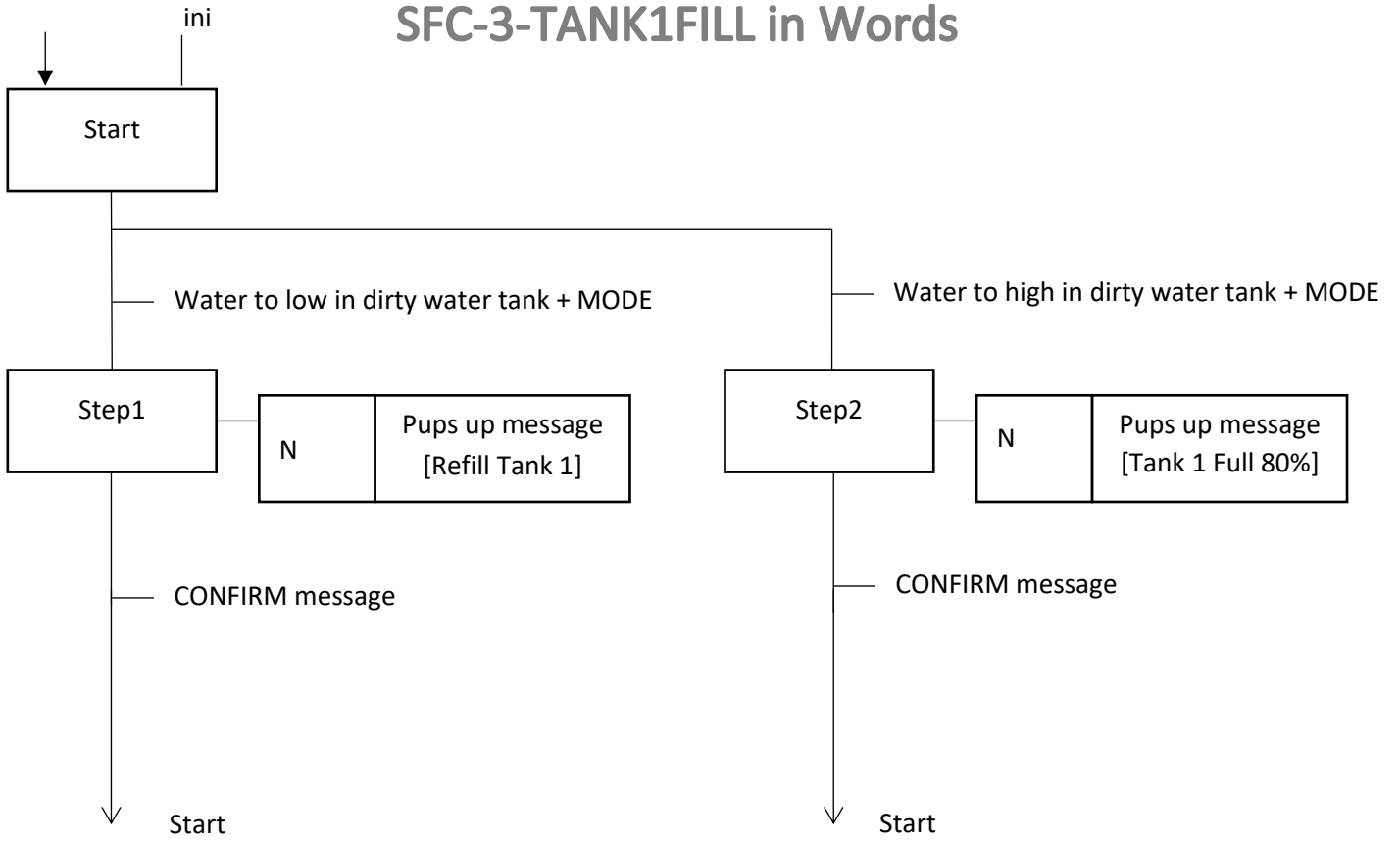

# SFC-3-TANK1FILL

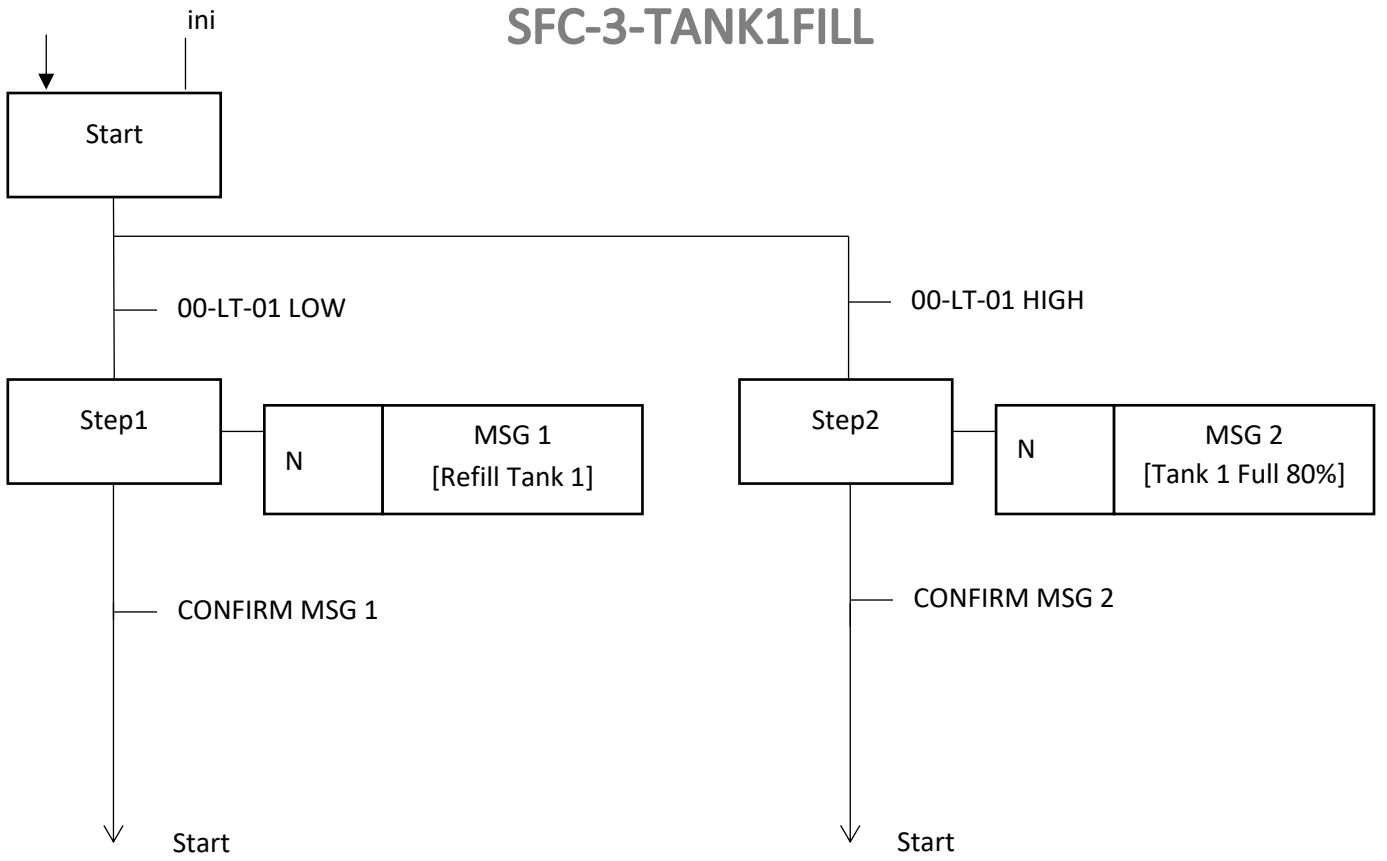

# SFC-4-BACKWASH in Words

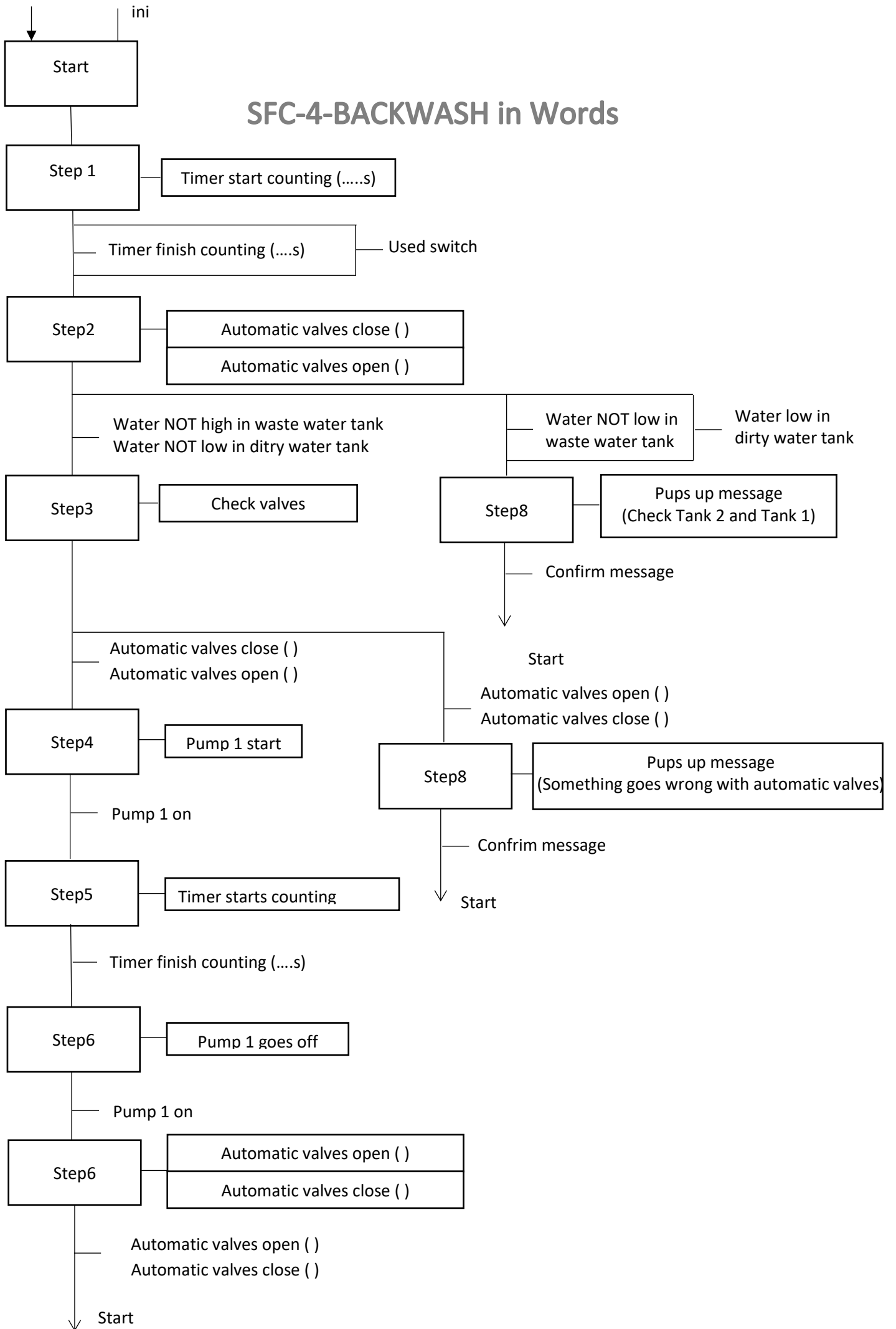





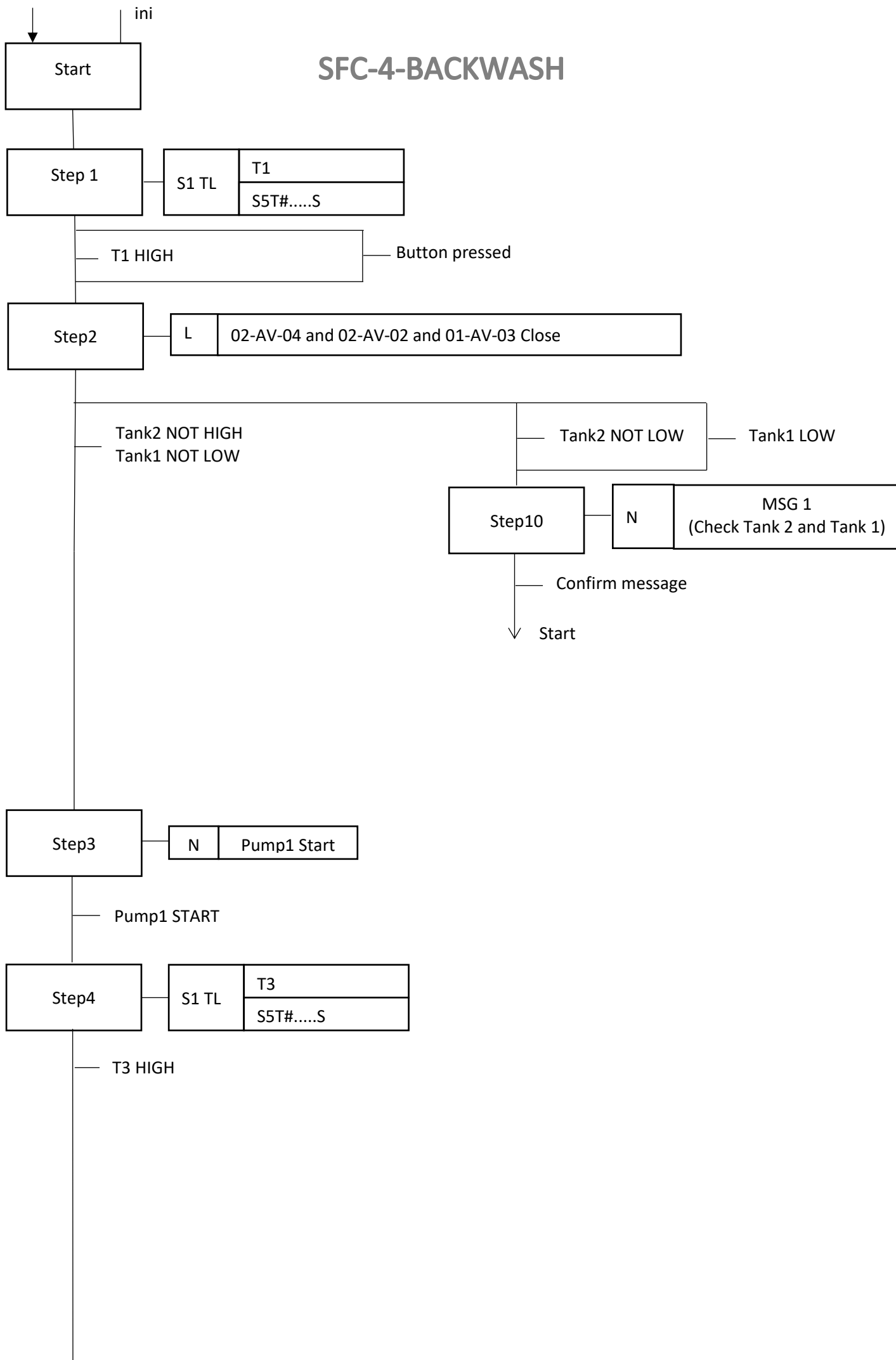

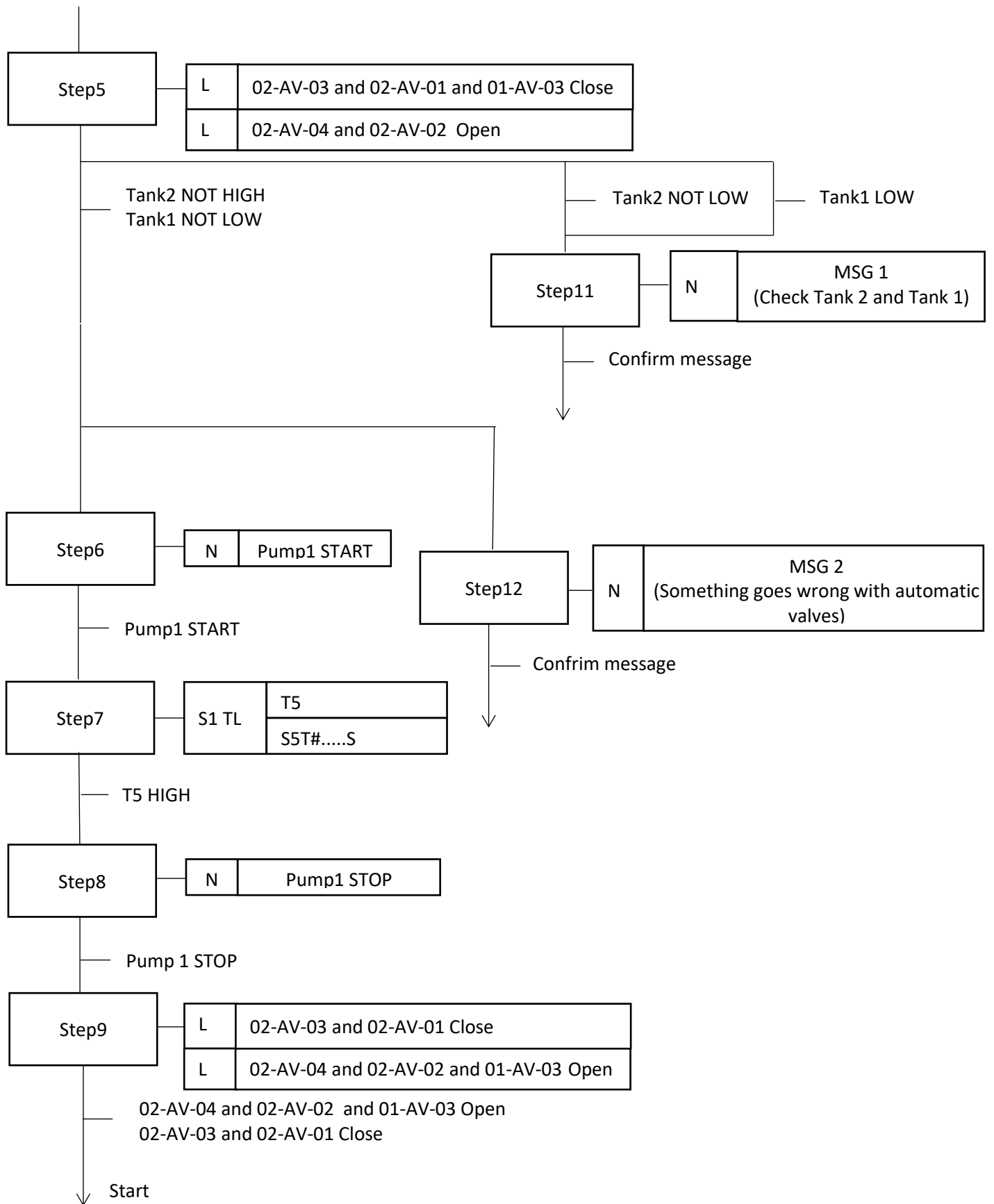



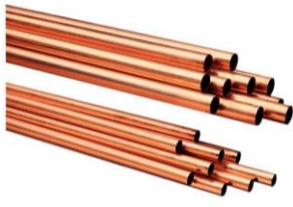

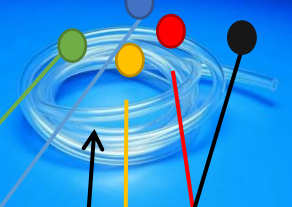

# SFC-4-BACKWASH

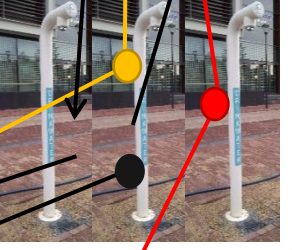
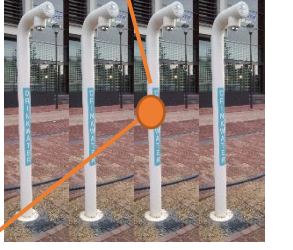

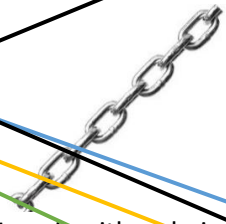

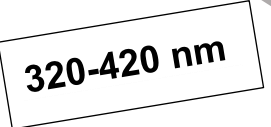

<p>Pipe work</p>	 <p>Copper</p>	 <p>Not transparent plastic</p>	 <p>Transparent plastic</p>	 <p>Stainless steel</p>	 <p>Steel</p>	
<p>Tappoint</p>	 <p>1 point</p>	 <p>2 points</p>	 <p>3 points</p>	 <p>4 points</p>		
<p>Fixing filter-unit</p>	 <p>Frame</p>	 <p>Hang it with a chain</p>	 <p>Cabinet</p>			
<p>UV-Filter</p>	 <p>UV-A</p>	 <p>UV-B</p>	 <p>UV-C</p>			