

PAPER • OPEN ACCESS

## A comparison between Series Dynamic Resistors and CROWBAR circuit protection for LVRT capability of Doubly-Fed Induction Generator

To cite this article: Yassir El Karkri *et al* 2018 *IOP Conf. Ser.: Earth Environ. Sci.* **161** 012012

View the [article online](#) for updates and enhancements.

You may also like

- [Research and Application of Low Voltage Ride through \(LVRT\) and the Power Grid Adaptability Testing Device for Frequency Converter](#)  
Xu Zaide, Liu Yang, Xu Jingmin et al.
- [Validation of a CT-based motion model with \*in-situ\* fluoroscopy for lung surface deformation estimation](#)  
M Ranjbar, P Sabouri, S Mossahebi et al.
- [Electromechanical Transient Modeling and LVRT Parameter Identification of Large Capacity Full Power Converter Wind Turbines Based on PSASP Program](#)  
Guoqiang Lu, Xiangyu Tao, Chunmeng Chen et al.



245th ECS Meeting • May 26-30, 2024 • San Francisco, CA

Don't miss your chance to present!

Connect with the leading electrochemical and solid-state science network!

Deadline Extended: December 15, 2023

Submit now!



# A comparison between Series Dynamic Resistors and CROWBAR circuit protection for LVRT capability of Doubly-Fed Induction Generator

Yassir EL KARKRI<sup>1,\*</sup>, Hassane EL MARKHI<sup>1</sup>, Tijani LAMHAMDI<sup>1</sup>, Hassan EL MOUSSAOUI<sup>1</sup>

<sup>1</sup>The Signals, Systems and Components Laboratory, Sidi Mohamed Ben Abdellah University, FST Fez, Morocco

\*yassir.elkarkri@usmba.ac.ma

**Abstract.** In this paper, we will focus on a comparison between two strategies (the Series Dynamic Resistors (SDR) and CROWBAR circuit for Low Voltage Ride Through (LVRT) capability of Doubly-Fed Induction Generator (DFIG), in order to determine different responses of reactive power and active power during the grid faults in line with the requirements determined by the grid codes (GCs). The two strategies are simulated by using MATLAB/Simulink environment

## 1. Introduction

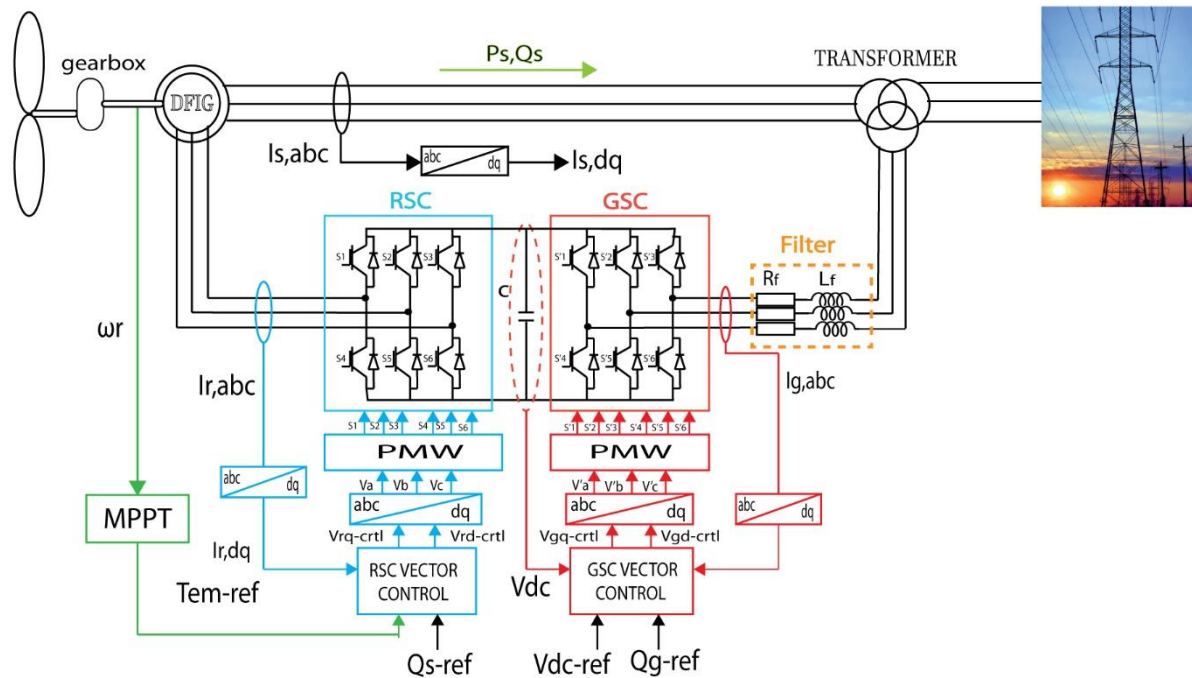
The electricity produced from nuclear and fossil energy has grown significantly across these last years. In fact, those classical energy sources have a serious environment impact. Therefore, the emerging ecological knowledge has greatly enhanced the interest in renewable energies integration [1]. Wind energy is one of these several clean energies sources. This technology has been having a fast development and has been attained a level of maturity during these last years. So its integration in the grid has a big interest by researchers [2].

Actually, DFIG is the most used generator in the wind power area, the wind turbine is connected to the DFIG rotor through a gearbox that adapts the wind speed generated from wind blades to the DFIG. The grid is directly connected to the DFIG stator windings and to the DFIG rotor windings via a back-to-back power converter [3] as shown in Figure 1. In addition, a filter is coupled to the grid to attenuate harmonic effects created by these converters (Figure 1). The Rotor Side Converter (RSC) is used in order to regulate the active power transported between DFIG and the grid [4]. However, the Grid Side Converter (GSC) is utilized to regulate the reactive power transferred to the grid. The aim of the Maximum Power Point Tracking (MPPT) block is to optimize the energy conversion of the Wind Turbine Generator (WTG) and then estimate torque reference [5]. It is used with reactive power reference and dq-axis rotor currents as inputs to the RSC control block. Therefore, the Pulse Width Modulation (PWM) signals are generated from the RSC control block output after been transformed to abc-axis (Figure 1). The GSC control block proposes to regulate the power factor and to control DC-link voltage. Thus, the block inputs are: the DC-link measured, dq-axis filtered grid currents, DC-link



voltage reference and active power reference. Therefore, PWM signals are generated from the GSC control block outputs after been transformed to abc-axis [6].

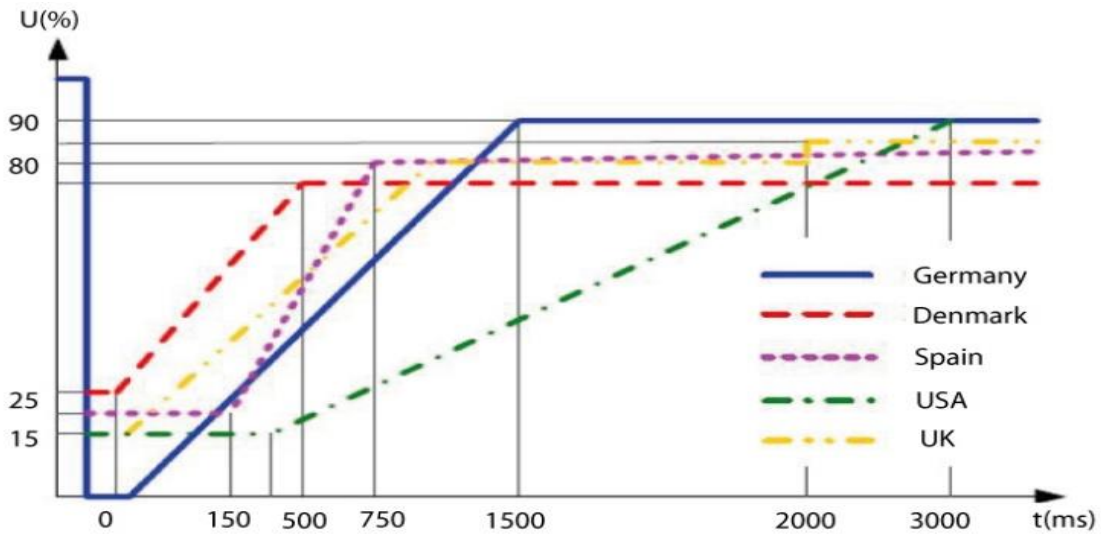
The command used for the converter is the vector control (Figure 1), also called field-oriented control, is a method of controlling power inverters in which the stator and rotor three-phase alternating currents are transformed into two orthogonal components which can be considered as vectors. The first vector allows adjustment of the magnetic flux of the motor, while the second regulates the torque. Thus, the vector control comes to solve this problem of decoupling the flux inside the machine from that of the torque.



**Figure 1.** DFIG based wind turbine connected to the grid.

In the past, during a grid fault, WTGs has disconnected from the GRID. Actually, to remain these WTs connected to GRID even if a fault occurs, new requirements exist. In fact, during these last years, many countries have proved their GCs in transmission and distribution. These codes specify voltage conditions ranges for which WTGs have to keep connected to the power electric system [7]. As WTGs become higher and level of penetration becomes larger in the grid, so the grid operators had to change the GC [8].

LVRT is a section of the GC fixed for the grid voltage dips, such as WTGs are required to stay connected to the grid for a considered time before being allowed to disconnect. This considered time can be changed from one GC to another depends on the severity of the fault. Figure 2 shows differences between these codes during voltage dips in different countries [9, 10]. This paper presents a comparison between two LVRT strategies. (i): the SDR with bypass switching devices coupled with stator windings. (ii): the CROWBAR circuit which consists of a controllable switch and a dissipation resistor coupled between the RSC and the rotor windings.



**Figure 2.** LVRT Requirements of the wind farms in different countries [8].

This paper is structured as: In the second section, the scheme of the CROWBAR circuit is presented. In the third section, the principle of the SDR strategy is presented. The simulation results of the SDR compared with the CROWBAR strategy is given in the fourth section. Finally, the conclusion is summarized in the fifth section.

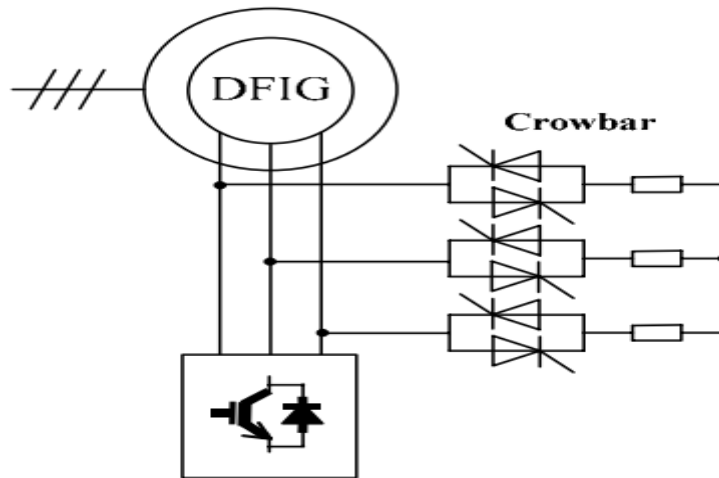
## 2. Crowbar circuit protection

A voltage limiting circuit “CROWBAR” is usually implemented between the rotor windings and its electronic power converter to provide an electrical bypass circuit for the transient current induced by the voltage drops.

Initially, the solution implemented was simply to short-circuit the rotor with a CROWBAR circuit. The CROWBAR circuit is connected to the rotor windings and the RSC. A triac can be used as a controllable switch for CROWBAR circuit as shown in Figure 3. The semiconductors are supposed ideal, and a global connection function  $S_c$  is fixed for this three-phase electronic switch. It takes values 1, when the switch is closed and 0 when it is open. Thus, the voltage limiting circuit can be modelled by a simple equation:

$$v_{c\text{-bar}} = S_c R_{\text{crowbar}} i_{\text{crowbar}} \quad (1)$$

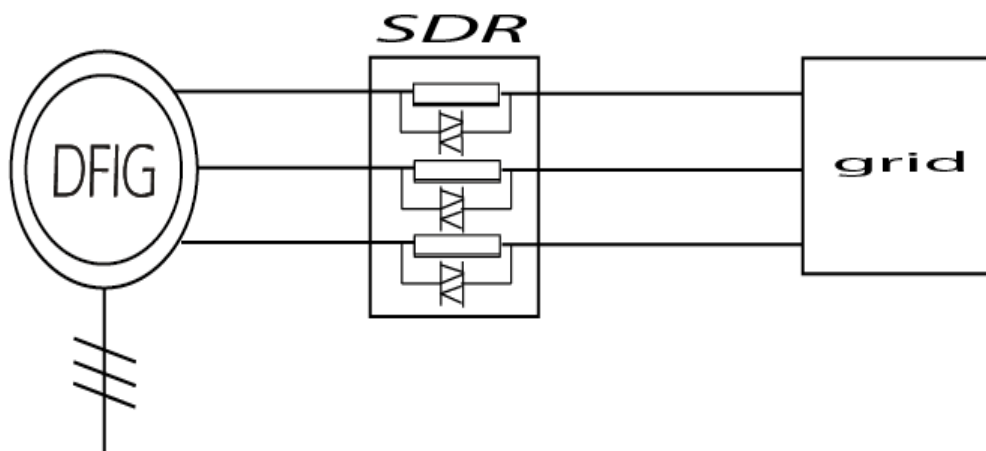
The behavior of this type of system is very impressed by the value of the dissipation resistances. It has been demonstrated by simulation that a low-value resistor drives to an increase in electromagnetic torque, high over-currents, and low rotor voltage [11]. In opposite, a high value for the resistance will be translated by a decrease in the electromagnetic torque and electric currents, but higher voltages crossed the rotor. Therefore, the resistors must be low enough to avoid over-voltages on the power converters. Also, they must be high enough to limit rotor current. In our study, this resistance value is taken to be equal to  $30 R_r$  (the resistance of the rotor windings)



**Figure 3.** DFIG with CROWBAR coupled with ROTOR windings.

### 3. Series Dynamic Resistors

This method consists to coupled resistors in series with the stator (Figure 4), in order to raise the stator voltage and to decrease the DC component at the flux during the voltage sags, this would limit over-voltages at the rotor and therefore avoid peaks in rotor current [12].



**Figure 4.** DFIG with SDR coupled with stator windings.

The determination of the value of the dynamic resistance is necessary, a high-value resistor will produce a large dissipation of energy and can pass the maximum value of the stator windings voltages. On the opposite, a low-value resistor cannot limit the fault current. So the dimensioning of the resistance is defined according to two conditions:

The resistors must be high enough to limit the rotor voltage to the maximum input voltage allowed by the converter, in order to avoid the damage of RSC control. Equation (2) expresses the case where the value of rotor voltage have to not exceed the maximum RSC voltage.

$$v_{r,max} < V_{RSC,max} \quad (2)$$

Since the RSC can only produce a voltage lower than the DC voltage, its maximum output value  $V_{RSC,max}$  is calculated as follows:

$$V_{RSC,max} = \frac{V_{dc}}{2\sqrt{\frac{2}{3}}} \quad (3)$$

The resistors must be small enough to limit the stator voltage from exceeding his maximum value. Equation (3) indicates the condition which the SDR maximum voltage value adding to the grid voltage has to not pass the maximum stator voltage.

$$V_{SDR,max} + v_{grid} < V_{S,max} \quad (4)$$

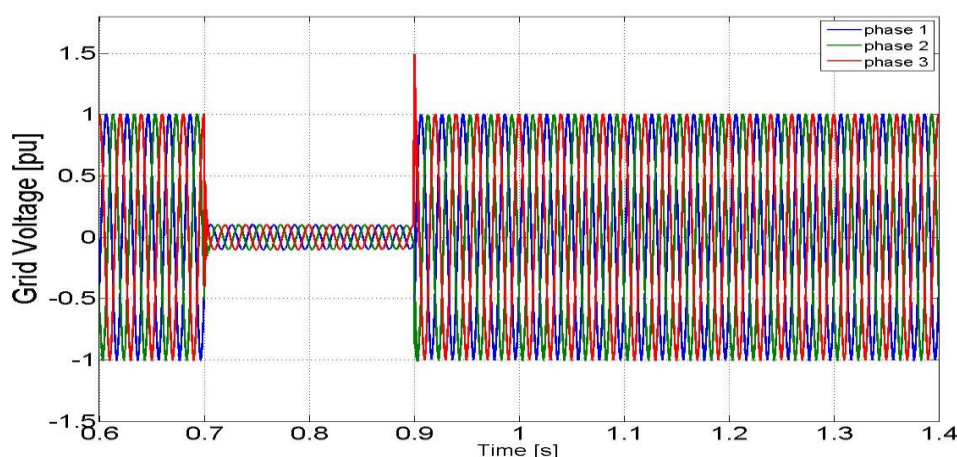
Replacing  $V_{SBR}$  by  $V_{SBR} = R_{SBR} I_s$ , and we considered the worst case for grid fault when  $v_{grid} = 0V$ .

$$\frac{1}{I_s} \left( (1-g)V_1 - \frac{M}{L_s} \frac{V_{dc}}{2\sqrt{\frac{2}{3}}} \right) \leq R_{SDBR} \leq \frac{V_{Smax}}{I_s} \quad (5)$$

We found:  $0.05pu \leq R_{SDBR} \leq 1.25 pu$

#### 4. Simulation and results

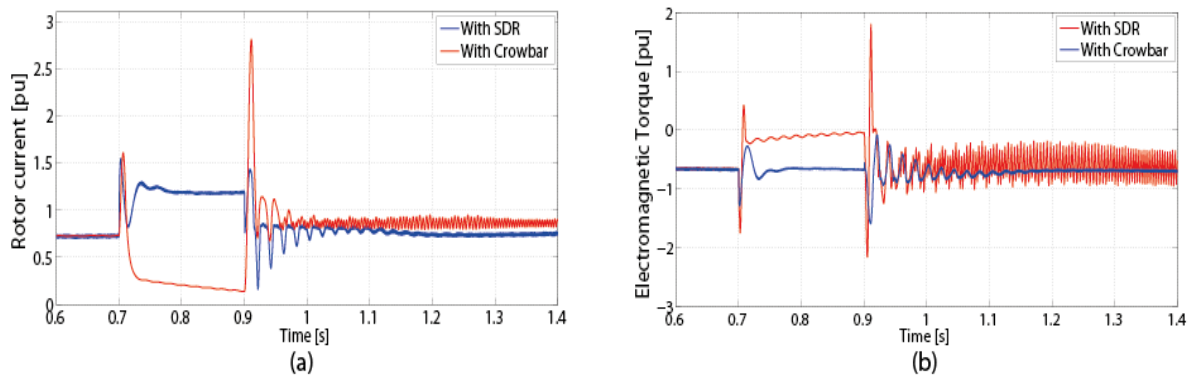
The system under study, presented in Figure 1, consists of a 1.5MW wind turbine. In this comparison, the tests were conducted using MATLAB/SIMULINK software, coherent model of the generator is used. The DFIG ride through capability is simulated for a three-phase voltage dip, in which the grid voltage in three-phase drops to 10% of its nominal value (90% voltage dip) at  $t=0.7s$  and remains for 0.9s (Figure 5).



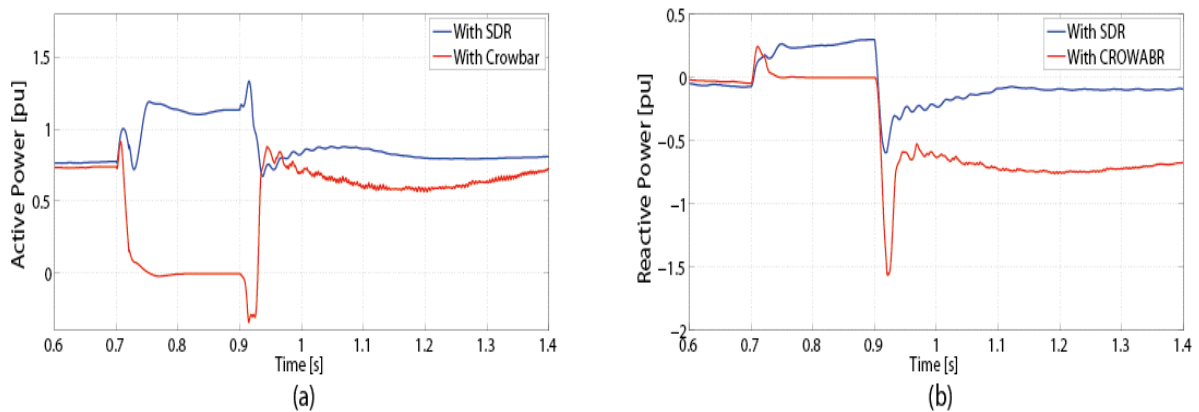
**Figure 5.** Simulation of voltage dips applied.

In this paper, two distinct strategies are investigated and compared in figure 6 and figure 7. In the first case, the SDR is applied (the blue curve), and the second case demonstrates the DFIG with the CROWBAR circuit protection (the red curve).

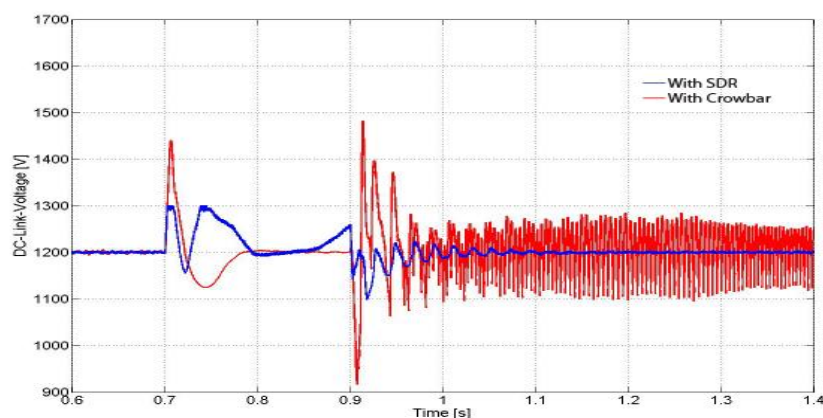




**Figure 6.** Simulation results of (a) rotor current and (b) Electromagnetic torque with SDR (blue) and with CROWBAR (red).



**Figure 7.** Simulation results of (a) Active power and (b) Reactive power with SDR (blue) and with CROWBAR (red).



**Figure 8:** Simulation results of DC-voltage with SDR (blue) and with CROWBAR (red).

Figure 6 illustrates (a) Rotor current, (b) Electromagnetic torque and Figure 7 represent (a) Active Power, (b) Reactive power, with the SDR (the blue curve) and with the CROWBAR circuit protection (the red curve). By utilizing the SDR method, the simulations show positive results, thus the electrical values of active power, rotor current, electromagnetic torque and reactive power have passed to reasonable values and much better than those obtained using the CROWBAR circuit protection, it is

noted that the improvement of the electrical values above-mentioned will allow: The wind turbine to still connected to the grid for a long times without much stress and without making any damage to the devices of the wind turbine. Also, to avoid mechanical stress due to the important oscillations during a grid fault, so with SDR solution the oscillations and the influence on the functioning of the DFIG including power converters and capacity are significantly degraded. In addition, the the system with can support grid power quality through the fault. From Figure 8 we remark that the DC-link voltage is almost substantial, by using SDR which remains the safety and the stability of the DC link.

As result, the wind turbine equipment will be well protected and the important cost of replacement of such devices will be avoided, in addition, the wind turbine working time is maximized. Also, with the SDR, the reactive power can restore quickly its normal state in order to ensure the electrical system stability. On the other hand, with the use of CROWBAR circuit protection it is observed that during the grid fault the rotor current and the active power almost zero due to separating of the converters from the rotor which misses the control of DFIG, this impact will result frequent disruptions of the wind turbine, current and accidental disconnections of the wind turbine from the grid, poor quality of service, GC not respected, very high maintenance cost and the cost of the wind turbines disconnection is very penalizing for both the producers and the grid operators.

## 5. Conclusion

This paper presents a comparison between the CROWBAR circuit protection and the SDR. The second strategy which based on the use of SDR coupled with stator windings is significant decreases the height values of the rotor currents, reduces the oscillations of the electromagnetic torque at the instants of occurring and clearing the grid faults. Also, the active power stays in the admitted DFIG operation range (0.7pu and 1.3pu) and the reactive power takes its normal value quickly after the fault disappear compared to CROWBAR circuit protection, which improves the LVRT capability of the DFIG. Therefore, the SDR solution is more efficient than the CROWBAR solution.

## References

- [1] Ostolaza, Joseba Xabier, Aitor Etxeberria, and Itziar Zubia. 2015 Wind farm node connected DFIG/back-to back converter coupling transient model for grid integration studies. *Energy Conversion and Management*. **106** 428-439.
- [2] Cheng M, and Zhu Y 2014 The state of the art of wind energy conversion systems and technologies: A review. *Energy Conversion and Management*. **88** 332-347.
- [3] Dinesh S, Meenakshi R, Suhanya M S, Kumaran M S and Muthu R 2014 Modeling and direct power control of DFIG for wind energy conversion system with a back to back converter. *Green Computing Communication and Electrical Engineering ICGCCEE International Conference on IEEE* 1-6.
- [4] Abad G, Lopez J, Rodriguez M A, Marroyo L and Iwanski G 2011 Vector Control Strategies for Grid-Connected DFIM Wind Turbines. *Doubly Fed Induction Machine: Modeling and Control for Wind Energy Generation* 303-361.
- [5] Mehdipour C, Hajizadeh A, and Mehdipour I 2016 Dynamic modeling and control of DFIG-based wind turbines under balanced network conditions. *International Journal of Electrical Power and Energ Systems* **83** 560-569.
- [6] Xiang D, Ran L, Tavner P. J, and Yang S 2006 Control of a doubly fed induction generator in a wind turbine during grid fault ride-through. *IEEE Transactions on Energy Conversion* **21**(3) 652-662.



- [7] Mullane A, Lightbody G, & Yacamini R 2005 Wind-turbine fault ride-through enhancement. *IEEE Transactions on Power Systems* **20(4)** 1929-1937.
- [8] Boukhris Y., El Makrini A., El Moussaoui H and El Markhi H. 2015. Low Voltage Ride-through Capability Enhancement of Doubly Fed Induction Generator Based Wind Turbines under Voltage Dips. *International Journal of Power Electronics and Drive Systems* **6(4)**.
- [9] Wilch M, Pappala V S, Singh S N and Erlich I 2007 Reactive power generation by DFIG based wind farms with AC grid connection. *Power Tech, IEEE Lausanne* 626-632.
- [10] Lima F K, Luna A, Rodriguez P, Watanabe E H and Blaabjerg F 2010 Rotor voltage dynamics in the doubly fed induction generator during grid faults. *IEEE Transactions on power electronics* **25(1)** 118-130.
- [11] Lohde R, Jensen S and Knop A 2007 Analysis of three phase grid failure on doubly fed induction generator ride-through using Crowbars. *Power Electronics and Applications European Conference on IEEE* 1-8.
- [12] El Makrini A, El Karkri Y, Boukhriss Y, El Markhi H and El Moussaoui H 2017 LVRT Control Strategy of DFIG Based Wind Turbines Combined the Active and Passive Protections. *International Journal of Renewable Energy Research IJRER*, **7(3)** 1258-1269.